

## Engineering Case Studies

1	Adding sound waves	2
2	Complex representation of sound waves and sound reflection	7
3	Sensitivity of microphones	10
4	Refraction	13
5	Beam deformation	15
6	Deflection of a beam	20
7	Buckling of columns	26
8	Maximum bending moment for a multiple structure	35
9	Equation of the curve of a cable fixed at two end points	40
10	Critical water height in an open channel	45
11	Simple pendulum	50
12	Motion of a pendulum	51
13	The falling snowflake	56
14	Satellite motion	60
15	Satellite orbits	63
16	Underground railway signal location	72
17	Heat conduction through a wine cellar roof	76
18	Two-dimensional flow past a cylindrical obstacle	80
19	Two-dimensional flow of a viscous liquid on an inclined plate	86
20	Force on a cylinder due to a two-dimensional streaming and swirling flow	91

### *Learning outcomes*

*This Workbook offers a compendium of Engineering Case Studies as an additional teaching and learning resource to those included in the previous workbooks.*

*The Workbook is intended to reinforce notions of modelling using an increasingly wide cross section of mathematical techniques.*

# Engineering Case Studies

48



## Introduction

This Workbook offers a compendium of Engineering Case Studies as an additional teaching and learning resource to those included in Workbooks 1 to 47. The mathematical topics and the relevant Workbooks are listed at the beginning of each Case Study.

The Workbook is intended to reinforce notions of modelling using an increasingly wide cross section of mathematical techniques.



# Engineering Case Study 1

## Adding sound waves

### Mathematical Skills

Topic	Workbook
Trigonometry	[4]
Second order ODEs	[19]

### Introduction

Waves and mathematical models for waves are important in many aspects of engineering. This mini-case study introduces these representations and introduces other wave-related ideas. It makes use of differential equations and trigonometry. The nature and the terminology of wave motion may be introduced with reference to oscillations of a mass on a spring. A fundamental property of any linear spring was discovered by Robert Hooke in the 17th century and is known as Hooke's law. Hooke expressed his finding by stating *the power of any springy body is in the same proportion with the extension*. Using more modern terminology, Hooke's law may be stated as *if any elastic material is distorted, the force produced in the material is proportional to the amount of distortion*. An algebraic statement of the law, with the notation  $F$  for the force,  $x$  for the amount that the spring is extended and  $K$  for the constant of proportionality, is

$$F = -Kx \quad (1)$$

The negative sign arises because the force is in the opposite direction to the extension.

Consider the motion of a mass ( $M$ ) attached to a horizontal (massless) spring the other end of which is connected to a fixed point. After an initial displacement the mass moves on a frictionless horizontal slide.

The motion of the mass can be described by Newton's second law, which states that force is equal to mass multiplied by acceleration ( $a$ ):

$$F = Ma$$

Acceleration is the rate of change of velocity  $v$ , i.e.  $\frac{dv}{dt}$ , and velocity is the rate of change of position  $x$ , i.e.  $\frac{dx}{dt}$ , so  $a = \frac{d^2x}{dt^2}$  and

$$F = M \frac{d^2x}{dt^2} \quad (2)$$

Equating (1) and (2), the equation describing the motion of the mass is

$$M \frac{d^2x}{dt^2} = -Kx$$

The general solution to this second order differential equation (see HELM 19.4, subsection 2) is

$$x = C \cos \left( \sqrt{\frac{K}{M}} t \right) + D \sin \left( \sqrt{\frac{K}{M}} t \right)$$

If the mass starts from rest and is released when the displacement from the rest position is  $C$ , then  $x = A$  at  $t = 0$ . Also  $\dot{x} = 0$  at  $t = 0$ . Use of either of these initial conditions means that  $D = 0$ , so

$$x = A \cos \left( \sqrt{\frac{K}{M}} t \right)$$

This represents oscillation about  $x = 0$  with amplitude  $A$  and angular frequency  $\omega_n = \sqrt{(K/M)}$  (the **angular natural frequency** of the motion). A complete cycle of oscillation occurs in time  $T$  such that  $T = 2\pi\sqrt{(K/M)}$  and  $T$  is the period of the oscillation.

The **natural frequency** of the resulting motion,  $f_n$ , can be deduced from  $\omega_n = 2\pi f_n$ . The resulting motion is known as **simple harmonic motion**.

Air molecules behave as small masses on springs and move to and fro during the passage of a sound wave. Small amplitude sound waves consist of sinusoidally alternating compressions and rarefactions in the medium supporting the sound. Typically sound waves contain many frequencies simultaneously. At some fixed location, the associated variation of air pressure  $p$  with time  $t$  about the ambient or equilibrium pressure in a **single frequency** (sometimes called **monochromatic**) plane sound wave can be represented by:

$$p = A \cos(\omega t + \phi)$$

where  $A$  is the **amplitude** of the wave,  $f = \omega/2\pi$  is its frequency and  $\phi$  is a fixed angle called the **phase**.

Since sine and cosine waves are identical except for a phase difference of  $\pi/2$  (which can be included by modifying the phase angle  $\phi$ ), we can also represent a sound wave by:

$$p = A \sin(\omega t + \phi)$$

### Problem in words

- Find the amplitude and phase resulting from the combination of two sound waves of the same frequency, the first of which has twice the amplitude of the second and the second has a **phase lead** of  $45^\circ$ .
- What is the result of combining two unit amplitude sound waves that have zero phase but a frequency difference of  $\delta/2\pi$ ?

### Mathematical statement of problem

- Find expressions for  $A$  and  $\phi$  such that

$$A \sin(\omega t + \phi) = 2 \sin(\omega t) + \sin\left(\omega t + \frac{\pi}{4}\right)$$

- Find expressions for  $A$  and  $\omega'$  such that

$$A \sin(\omega' t) = \sin(\omega t) + \sin[(\omega + \delta)t]$$

### Mathematical analysis

- Using the trigonometric formula  $\sin(X + Y) \equiv \sin X \cos Y + \cos X \sin Y$ , gives

$$A \sin(\omega t + \phi) = A \sin(\omega t) \cos \phi + A \cos(\omega t) \sin \phi$$

$$\begin{aligned}
&= 2 \sin(\omega t) + \sin\left(\omega t + \frac{\pi}{4}\right) \\
&= 2 \sin(\omega t) + \frac{\sin(\omega t)}{\sqrt{2}} + \frac{\cos(\omega t)}{\sqrt{2}} \\
&= \left(2 + \frac{1}{\sqrt{2}}\right) \sin(\omega t) + \frac{1}{\sqrt{2}} \cos(\omega t)
\end{aligned}$$

This means

$$A \cos \phi = 2 + \frac{1}{\sqrt{2}} \quad \text{and} \quad A \sin \phi = \frac{1}{\sqrt{2}}$$

So

$$A^2 \cos^2 \phi + A^2 \sin^2 \phi = A^2 = \left(2 + \frac{1}{\sqrt{2}}\right)^2 + \frac{1}{2} = 5 + 2\sqrt{2} = 7.828 \quad (\text{to 3 d.p.})$$

i.e.  $A = 2.8$  (to 1 d.p.)

Substitution in either of the equations involving both  $A$  and  $\phi$  gives  $\phi = 14.63^\circ$ .

(b) Using the trigonometric relationship

$$\sin X + \sin Y \equiv 2 \sin\left(\frac{X+Y}{2}\right) \cos\left(\frac{X-Y}{2}\right), \quad \text{with } X = \omega t \text{ and } Y = (\omega + \delta)t$$

gives

$$\begin{aligned}
&\sin(\omega t) + \sin[(\omega + \delta)t] \\
&= 2 \sin\left(\frac{\omega t + (\omega + \delta)t}{2}\right) \cos\left(\frac{\omega t - (\omega + \delta)t}{2}\right) \\
&= 2 \cos\left(\frac{\delta}{2}t\right) \sin\left(\left(\omega + \frac{\delta}{2}\right)t\right)
\end{aligned}$$

This has the form  $A \sin(\omega't)$  if

$$A = 2 \cos\left(\frac{\delta}{2}t\right) \quad \text{and} \quad \omega' = \omega + \frac{\delta}{2} = \frac{\omega + (\omega + \delta)}{2}$$

$\omega'$  represents the angular frequency of the combined wave.

## Interpretation

- (a) The amplitude of the wave formed by combining waves with different amplitudes and phases is not simply the sum of the individual component wave amplitudes (which would be  $2+1 = 3$ ). The phase of the combined wave is less than that of the leading component.
- (b) The amplitude of the combined wave varies with time between  $+2$  and  $-2$  at an angular frequency that is half of the difference between angular frequencies of the component waves. The frequency of the wave formed by combining unit (or same) amplitude components with different frequencies is the mean of the frequencies of the component waves. A listener would hear the combined wave as a sound with fluctuating volume i.e. would hear **beats** between component waves. For example if two sounds with frequencies of 200 Hz and 2005 Hz are played together the resulting wave has a frequency of 2002.5 Hz and a volume that fluctuates at a frequency of 5 Hz. Although the pressure would be fluctuating at a frequency of 2.5 Hz, the negative part of the fluctuation would not be heard.



# Engineering Case Study 2

## Complex representation of sound waves and sound reflection

### Mathematical Skills

Topic	Workbook
Trigonometry	[4]
Complex numbers	[10]

### Introduction

Complex exponential expressions turn out often to be more convenient to handle than the trigonometric functions (sine and cosine) to represent sound waves and their interaction with surfaces. The time dependence in a single frequency sound wave may be written

$$e^{-i\omega t} = \cos(\omega t) - i \sin(\omega t)$$

So  $\text{Re}[e^{-i\omega t}] = \cos \omega t$

If  $A$  is real then,  $\text{Re}[Ae^{-i\omega t}] = A \cos \omega t$ .

Similarly, using  $e^{-i(\omega t + \phi)} = \cos(\omega t + \phi) - i \sin(\omega t + \phi)$  then

$$\text{Re}[Ae^{-i(\omega t + \phi)}] = A \cos(\omega t + \phi)$$

The angle  $\phi$  is called the **phase** of the sound wave and determines the amplitude when  $t = 0$ , i.e.  $A \cos \phi$ . A **plane sound wave** is a wave in which the wave fronts (contours of equal phase) are plane and parallel. If a plane sound wave is reflected at the boundary between two media, then, in general, the reflected wave has different amplitude and phase from the incident wave. At the boundary, the incident wave with amplitude  $A_i$  may be represented by the complex exponential expression

$$p_i = A_i e^{-i\omega t}$$

The reflected wave may be represented by the complex exponential expression

$$p_r = A_r e^{i(\omega t + \phi)}$$

The reflected wave has the same angular frequency  $\omega$ , amplitude  $A_r$  and differs in phase from the incident wave by the phase angle  $\phi$ .

The ratio of the reflected wave to the incident wave ( $p_i/p_r$ ) is called the **reflection coefficient** ( $R$ ) of the boundary and is a *complex number*. It depends on the physical properties of the two media either side of the boundary.

The complex plane wave reflection coefficient is given by

$$R = \frac{p_r}{p_i} = \frac{A_r e^{-i(\omega t + \phi)}}{A_i e^{-i\omega t}} = \frac{A_r}{A_i} e^{-i\phi}$$

If the reflection coefficient of a boundary is written as  $a + ib$ , i.e.  $a$  is the real part and  $b$  is the imaginary part, then

$$a + ib = \frac{A_r}{A_i} e^{-i\phi} = \frac{A_r}{A_i} (\cos \phi - i \sin \phi)$$

Hence  $a = \frac{A_r}{A_i} \cos \phi$  and  $b = -\frac{A_r}{A_i} \sin \phi$

Dividing the second of these expressions by the first, gives

$$\tan \phi = -\frac{b}{a} \quad \text{or} \quad \arctan\left(-\frac{b}{a}\right) = \phi \quad (1)$$

Also

$$|R| = \sqrt{a^2 + b^2} = \sqrt{\frac{A_r^2}{A_i^2} \cos^2 \phi + \frac{A_r^2}{A_i^2} \sin^2 \phi} = \frac{A_r}{A_i} \quad (2)$$

Equations (1) and (2) relate the complex reflection coefficient phase and amplitude to its real and imaginary parts.

### Problem in words

For a particular boundary, the reflection coefficient is  $0.8 - 0.4i$ :

- Find the ratio of the reflected amplitude to the incident amplitude;
- Find the phase difference between the reflected wave and the incident wave
- What is implied about the phase shift at a surface if the reflection coefficient is  $+1$  or  $-1$ ?

### Mathematical statement of problem

- Use Equation (1) to determine the reflection coefficient amplitude;
- Use Equation (2) to determine the phase;
- Use Equations (1) and (2) to determine corresponding phase changes.

### Mathematical analysis

(a)  $|R| = |0.8 - 0.4i| = \sqrt{(0.8)^2 + (0.4)^2} = \sqrt{0.8} \approx 0.8944$

(b)  $\phi = \arctan\left(-\frac{b}{a}\right) = \arctan\left(\frac{0.4}{0.8}\right) = \arctan(0.5)$

Hence  $\phi \approx 0.4636$  radians  $\approx 26.57^\circ$

(c) If  $|R| = +1$  then  $b = 0$ . So  $\phi = \arctan\left(-\frac{b}{a}\right) = \arctan(0) = 0$

If  $|R| = -1 = e^{i\pi}$  then  $\phi = \pi$



## Interpretation

- (a) The magnitude of the reflection coefficient is 0.89. This means that the amplitude of the reflected wave is 0.89 of the incident wave.
- (b) There is a phase change of  $26.57^\circ$  at the boundary.
- (c)  $\phi = 0$  means zero phase change at the boundary. A boundary at which there is no change in amplitude or phase on reflection is called **acoustically hard**.

$\phi = \pi$  means that there is  $180^\circ$  phase change at the boundary. A boundary at which the reflected wave is  $180^\circ$  out of phase with the incident wave but there is no change in amplitude is called a **pressure release boundary**.

## Sensitivity of microphones

### Mathematical Skills

Topic	Workbook
Trigonometry	[4]
Integration	[13]
Mean value of a function	[14]

### Introduction

A microphone converts an incident sound (pressure wave in air) into an electrical signal, i.e. a fluctuating voltage, proportional to the average sound pressure. In a condenser (capacitor) microphone, incident sound causes vibration (mechanical motion) of the microphone diaphragm (a thin stretched and clamped membrane) in front of a fixed charged plate. This causes a variation in the electrical capacitance between the diaphragm and the plate and hence a varying voltage. This voltage is then amplified before being passed either to a recording system or to some form of sound analyser. Since the voltage output of a microphone depends on the average pressure on the microphone diaphragm, microphones respond differently to different frequencies of a sound wave depending on their size, shape and orientation with respect to the incident sound waves. Ideally the response of the microphone should be independent of frequency.

This mini-case study investigates how a simple model of a microphone diaphragm (as a rigid flat plate) and assumed incident plane sound waves can be used to predict the variation in performance of a microphone with frequency and angle of incidence.

The simple model is shown in Figure 3.1 together with a series of wavefronts in the incident wave. If the wavelength of the incident wave is much larger than the (microphone) plate width then the sound pressure will be nearly constant across the plate. If the wavelength is the same as the plate width then the average pressure will be zero. If the plate width is an integer number of wavelengths then, again the average pressure will be zero.

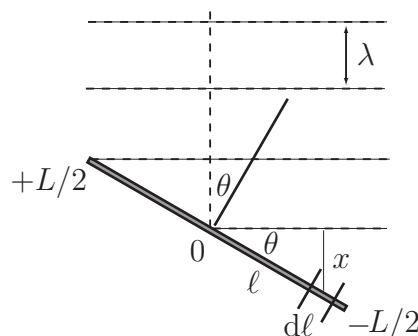

Figure 3.1: Plane sound wavefronts arriving at a rigid plate model of a microphone

### Problem in words

The microphone diaphragm is modelled as a flat rigid plate subject to single frequency sound waves incident at a given angle (see Figure 3.1). Derive an expression for the dependence of the average sound pressure on the plate on the incident sound frequency and use this expression to graph the frequency dependence of 25 mm and 12.5 mm wide microphones for sound at  $45^\circ$  incidence.

### Mathematical statement of problem

Given that the pressure variation about ambient of an incident plane sound wave travelling in the positive  $x$ -direction is represented by

$$p = A \cos(\omega t - kx) \quad (1)$$

where  $A$  is the amplitude,  $k (= 2\pi/\lambda)$  is the wavenumber corresponding to wavelength  $\lambda$ ,  $\omega (= 2\pi f)$  where  $f$  is the frequency) is the angular frequency,  $x$  is the coordinate in the direction of travel,  $t$  is the time and the plate width is  $L$  m,

- write down the pressure at the centre of the plate, if the centre of the plate is the origin ( $x = 0$ ) and  $t = 0$ .
- write down an expression for the pressure on the plate when  $t = 0$
- write down the relationship between  $\ell$ ,  $x$  and  $\theta$  where  $\ell$  is the distance from the centre and hence an expression for the pressure at distance  $\ell$  from the centre,
- write down an expression for the average pressure as the integral of the expression for pressure at distance  $\ell$  from the centre with respect to  $\ell$  between the limits of  $\pm L/2$  and carry out the integration,
- assume  $A = 1$  and substitute  $L = 25$  mm or 12.5 mm,  $\theta = 45^\circ$  in the result from (d); and graph the result for  $f$  between 0.2 and 100 kHz.

### Mathematical analysis

- From (1), for  $x = 0$  and  $t = 0$ , then  $p = A$ . So the pressure has a maximum at the centre of the plate.
- When  $t = 0$ , then  $p = A \cos(kx)$
- $x = \ell \sin \theta$ , hence at distance  $\ell$  from the centre

$$p = A \cos(k\ell \sin \theta)$$

- Using results from HELM 14.2 on calculating the mean value of a function

$$\begin{aligned} p_{av} &= \frac{1}{L} \int_{-L/2}^{+L/2} A \cos(k\ell \sin \theta) d\ell = \frac{A}{L} \frac{1}{\sin \theta} \left[ \sin(k\ell \sin \theta) \right]_{-L/2}^{+L/2} \\ &= \frac{A}{kL \sin \theta} \left[ \sin \left( \frac{kL \sin \theta}{2} \right) - \sin \left( -\frac{kL \sin \theta}{2} \right) \right] \\ &= \frac{2A}{kL \sin \theta} \sin \left( \frac{kL \sin \theta}{2} \right) \end{aligned} \quad (2)$$

(e) Using  $A = 1$ ,  $L = 0.025$  m (or 0.0125 m),  $k = 2\pi/\lambda$ ,  $c = f\lambda$ ,  $\theta = 45^\circ$  and  $c = 343$  m  $s^{-1}$  in (2) gives

$$p_{av} = \frac{343\sqrt{2}}{0.025\pi f} \sin\left(\frac{0.025\pi f}{343\sqrt{2}}\right) \quad \text{or} \quad p_{av} = \frac{342\sqrt{2}}{0.0125\pi f} \sin\left(\frac{0.0125\pi f}{343\sqrt{2}}\right)$$

Figure 3.2 shows the resulting graph.

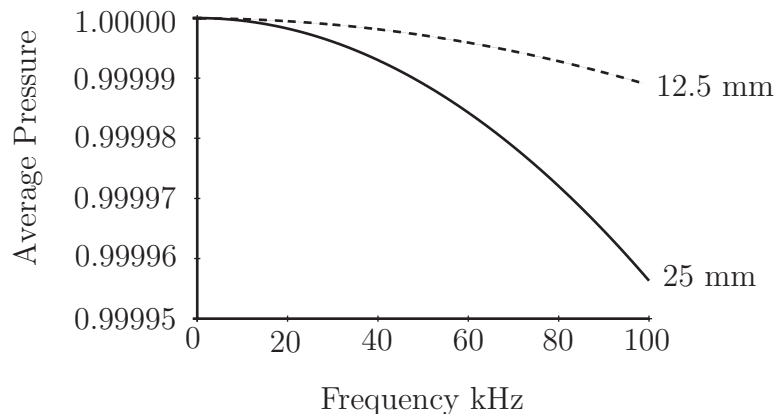

**Figure 3.2:** Predicted frequency response of 25 mm and 12.5 mm wide microphones

### Interpretation

The result (2) means that for  $\theta = 90^\circ$  (**normal** incidence) the average pressure is zero whenever  $L/\lambda$  is an integer as predicted in the introduction. For  $\theta \neq 90^\circ$ , (2) predicts that the average pressure has a minimum whenever  $L/\lambda$  is an integer. For  $\theta = 0$  (**grazing** incidence) or for near zero frequency  $f \rightarrow 0$  then use of the approximation  $\sin(x) \sim x$  for small  $x$  (radians) in (2) gives

$$\lim_{kL \sin \theta \rightarrow 0} p_{av}(f) \rightarrow A$$

So, for grazing incidence or near zero frequency, the simple microphone model predicts that the average pressure is independent of frequency.

Note in Figure 3.2 that the predicted average pressure and hence the sensitivity of the 25 mm microphone departs on the very sensitive scale used only from the ideal 'flat' response near 10 kHz. The result in (2) predicts that the sensitivity remains high at higher frequencies if the microphone is smaller. The response of a 12.5 mm microphone is predicted to depart from 'flat' nearer 20 kHz.



# Engineering Case Study 4

## Refraction

### Mathematical Skills

Topic	Workbook
Trigonometry	[4]
Differentiation	[11]

### Introduction

In Optics, Fermat's Principle states that when crossing a boundary where the refractive index changes, light will take the route (composed of straight line segments) of minimum travel time.

By considering a ray of light travelling from a medium with refractive index  $\mu_1$  to another with refractive index  $\mu_2$ , show that Fermat's Principle implies

$$\frac{\sin \theta_1}{\sin \theta_2} = \frac{\mu_2}{\mu_1}$$

where  $\theta_1$  and  $\theta_2$  are the angles that the light makes with the normal.

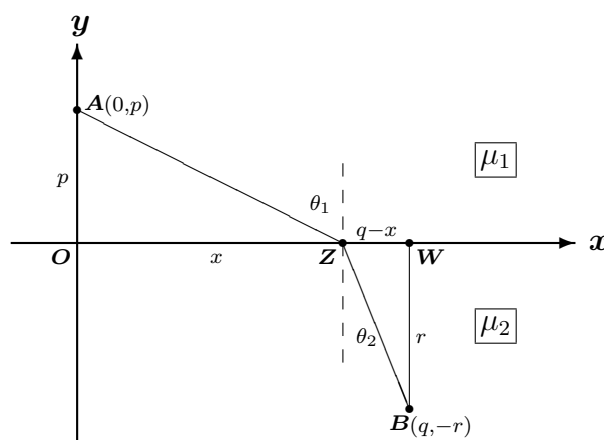

Figure 4.1

### Problem in words

The ray is travelling from  $A(0, p)$  to  $B(q, -r)$ , (with  $p, q, r > 0$ ) with refractive index  $\mu_1$  for  $y > 0$  and refractive index  $\mu_2$  for  $y < 0$ . Find the total travel time of the ray from  $A$  to  $B$  (in terms of  $x$ , the horizontal coordinate of point  $Z$ ) and find the condition for it to be a minimum.

(It may be assumed that the speed of light in a medium is given by  $v = \frac{c}{\mu}$  where  $\mu$  is the refractive index and  $c$  is the speed of light in a vacuum.)

### Mathematical analysis

Suppose that light travels from  $A$  to  $B$  via  $Z(x, 0)$ , then

- the velocity on stage  $AZ$  is  $c/\mu_1$  and on stage  $ZB$  is  $c/\mu_2$
- the length of stage  $AZ$  is  $\sqrt{x^2 + p^2}$  and of stage  $ZB$  is  $\sqrt{(q-x)^2 + r^2}$  (by Pythagoras)

Hence the travel time on stage  $AZ$  is  $\frac{\mu_1}{c} \sqrt{x^2 + p^2}$  and on stage  $ZB$  is  $\frac{\mu_2}{c} \sqrt{(q-x)^2 + r^2}$

giving a total travel time of

$$T = \frac{\mu_1}{c} \sqrt{x^2 + p^2} + \frac{\mu_2}{c} \sqrt{(q-x)^2 + r^2}$$

In order to find the value of  $x$  which minimises the travel time  $T$ , find  $\frac{dT}{dx}$  and the circumstances under which  $\frac{dT}{dx} = 0$ . Firstly

$$\begin{aligned} \frac{dT}{dx} &= \frac{\mu_1}{c} \cdot \frac{1}{2}(x^2 + p^2)^{-\frac{1}{2}} \cdot 2x + \frac{\mu_2}{c} \cdot \frac{1}{2}((q-x)^2 + r^2)^{-\frac{1}{2}} \cdot (-2(q-x)) \\ &= \frac{\mu_1}{c} \frac{x}{\sqrt{x^2 + p^2}} - \frac{\mu_2}{c} \frac{q-x}{\sqrt{(q-x)^2 + r^2}} \end{aligned}$$

Now, since  $\angle OAZ = \theta_1$  and  $\angle WBZ = \theta_2$  then

$$\sin \theta_1 = \frac{x}{\sqrt{x^2 + p^2}} \quad \text{and} \quad \sin \theta_2 = \frac{q-x}{\sqrt{(q-x)^2 + r^2}}$$

so

$$\frac{dT}{dx} = \frac{\mu_1}{c} \sin \theta_1 - \frac{\mu_2}{c} \sin \theta_2$$

and  $\frac{dT}{dx} = 0$  when

$$\frac{\mu_1}{c} \sin \theta_1 = \frac{\mu_2}{c} \sin \theta_2$$

or

$$\frac{\sin \theta_1}{\sin \theta_2} = \frac{\mu_2}{\mu_1}$$

### Interpretation

The result, which may be stated that the ratio of the sines of the angles of incidence and refraction at the boundary is the ratio of the refractive indices, is known as Snell's law. It is possible to show that  $\frac{d^2T}{dx^2} > 0$  when  $\frac{\sin \theta_1}{\sin \theta_2} = \frac{\mu_2}{\mu_1}$  (in fact  $\frac{d^2T}{dx^2} > 0$  for all values of  $x$ ) and hence that Snell's law represents the minimum rather than the maximum travel time. Alternatively, thinking about the shape of  $T=T(x)$ , it is possible to show that as  $x$  becomes very large then  $T$  becomes very large. Also, as  $x$  becomes very large and negative,  $T$  becomes very large (and positive), meaning that the stationary point in between these two extremes must be a minimum, i.e. Snell's law does indeed represent a minimum travel time. In view of the considered behaviour of the expression for the travel time over all values of  $x$ , the result corresponds to the overall minimum.



# Engineering Case Study 5

## Beam deformation

### Mathematical Skills

Topic	Workbook
Trigonometry	[4]
Definite integrals	[13]
First order ODEs	[19]

### Introduction

The beam is a fundamental part of most structures we see around us. It may be used in many ways depending as how its ends are fixed. One end may be rigidly fixed and the other free (called cantilevered) or both ends may be resting on supports (called simply supported). Other combinations are possible. There are three basic quantities of interest in the deformation of beams: the **deflection**, the **shear force** and the **bending moment**. For a beam which is supporting a distributed load of  $w$  (measured in  $\text{N m}^{-1}$  and which may represent the self-weight of the beam or may be an external load), the shear force is denoted by  $S$  and measured in N and the bending moment is denoted by  $M$  and measured in N m.

The quantities  $M$ ,  $S$  and  $w$  are related by

$$\frac{dM}{dz} = S \quad (1)$$

and

$$\frac{dS}{dz} = -w \quad (2)$$

where  $z$  measures the position along the beam. If one of the quantities is known, the others can be calculated from the Equations (1) and (2). In words, the shear force is the negative of the derivative (with respect to position) of the bending moment and the load is the derivative of the shear force. Alternatively, the shear force is the negative of the integral (with respect to position) of the load and the bending moment is the integral of the shear force. The negative sign in Equation (2) reflects the fact that the load is normally measured positively in the downward direction while a positive shear force refers to an upward force.

If a beam is called 'light', then its self-weight can be ignored. In many cases this is a perfectly reasonable assumption because the deformation caused by other forces is far more significant than that caused by self-weight.

If a load is called 'concentrated' then it may be regarded as acting at a single point. In reality all forces are distributed over some area even though the area might be very small.

## PART 1

### Problem in words

A cantilevered beam is constructed so that it is heavier in the centre than at the ends. Model the variation in load by  $w = w_o \left(1 + \sin \frac{\pi z}{L}\right)$  and then find the shear force and bending moment as functions of position along the beam.

### Mathematical statement of problem

Find the shear force  $S$  and the bending moment  $M$  for a cantilevered beam with weight varying as  $w = w_o \left(1 + \sin \frac{\pi z}{L}\right)$ . (Cantilevered means fixed at  $z = 0$  and free at  $z = L$ . Also, at the free end we have  $S = 0$  and  $M = 0$ .)

### Mathematical analysis

Equation (2) gives

$$S = - \int w dz = - \int w_o \left(1 + \sin \frac{\pi z}{L}\right) dz = -w_o \left[ z - \frac{L}{\pi} \cos \frac{\pi z}{L} \right] + C$$

At the free end ( $z = L$ ),  $S = 0$  so

$$0 = -w_o \left[ L - \frac{L}{\pi} (-1) \right] + C \quad \text{where } C \text{ is a constant.}$$

$$\text{so } C = w_o \frac{L}{\pi} + w_o L \quad \text{and} \quad S = -w_o \left[ z - \frac{L}{\pi} \cos \frac{\pi z}{L} \right] + w_o \frac{L}{\pi} + w_o L$$

This expression can be substituted into Equation (1) to give

$$\begin{aligned} M &= \int S dz = \int \left[ -w_o \left[ z - \frac{L}{\pi} \cos \frac{\pi z}{L} \right] + w_o \frac{L}{\pi} + w_o L \right] dz \\ &= -w_o \frac{z^2}{2} + \frac{L^2}{\pi^2} \sin \frac{\pi z}{L} + w_o \frac{L}{\pi} z + w_o L z + K \quad \text{where } K \text{ is a constant.} \end{aligned}$$

$M = 0$  when  $z = L$  so

$$0 = -w_o \frac{L^2}{2} + w_o \frac{L^2}{\pi} + w_o L^2 + K \quad \text{so} \quad K = w_o \frac{L^2}{2} - w_o \frac{L^2}{\pi} - w_o L^2$$

i.e.

$$M = -w_o \frac{z^2}{2} + \frac{L^2}{\pi^2} \sin \frac{\pi z}{L} + w_o \frac{L}{\pi} z + w_o L z + w_o \frac{L^2}{2} - w_o \frac{L^2}{\pi} - w_o L^2$$

Graphs of the loading, shear force and bending moments are given in Figure 5.1 on the next page.



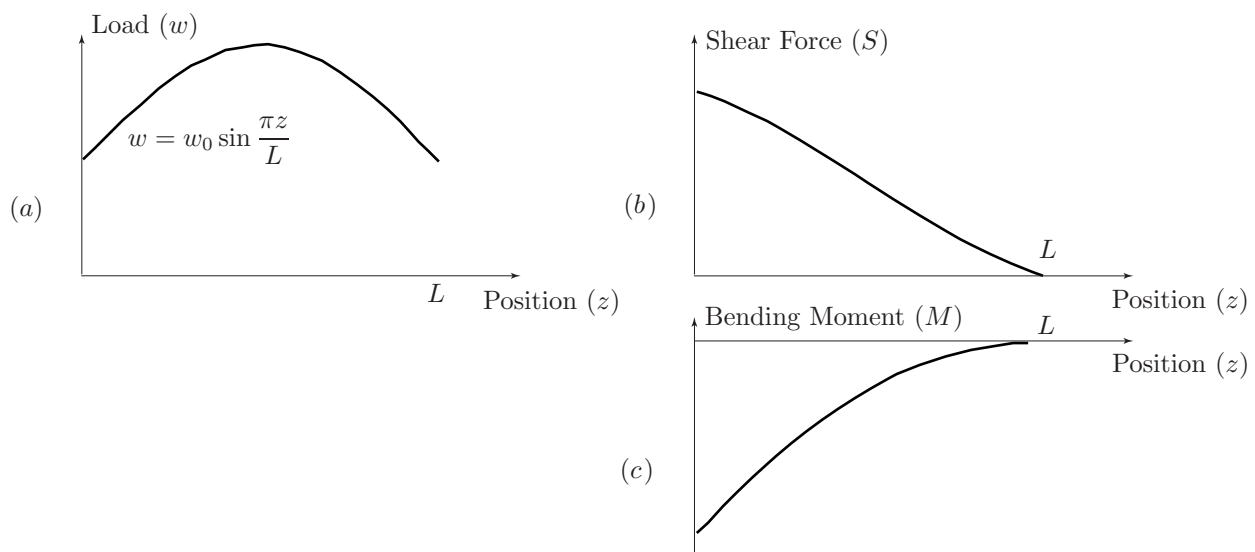

**Figure 5.1:** The loading (a), shear force (b) and bending moments (c) as functions of position  $z$

## PART 2

### Problem in words

A light beam supports a load concentrated at the free end. Find the shear force and bending moments as functions of position  $z$ .

### Mathematical statement of problem

A cantilevered beam supports a concentrated force  $W$  at the free end. Find the shear force  $S$  and bending moment  $M$  as functions of position  $z$  along the beam. Model the concentrated force with a force distributed over a small region of the beam.

### Mathematical analysis

The fact that the load is concentrated at a single point is not an insurmountable problem. It can be approximated by a load of  $W/\delta$  spread over the outer  $\delta$  length of the beam. As  $\delta$  approaches zero, the situation reverts to the one described in the example.

Equation (2) gives  $S = -\int w dz$ . In the outer  $\delta$  part of the beam, this becomes

$$S = -\int \frac{W}{\delta} dz = -\frac{W}{\delta} z + C.$$

At the extremity i.e. at  $z = L$ , the shear force is zero i.e.

$$0 = -\frac{W}{\delta} L + C \quad \text{giving} \quad C = \frac{WL}{\delta}.$$

So in the outer part of the beam

$$S = -\frac{W}{\delta} z + \frac{WL}{\delta} = \frac{W}{\delta} (L - z).$$

At the inner edge of where the load applies, i.e. at  $z = L - \delta$ ,

$$S = \frac{W}{\delta} (L - (L - \delta)) = \frac{W}{\delta} \delta = W.$$

For the main part of the beam, Equation (2) gives

$$S = - \int w dz = - \int 0 dz = C_1, \text{ where } C_1 \text{ is a constant.}$$

In order for the shear force to be continuous at  $z = L - \delta$ ,  $C_1$  should be set equal to  $W$ .

So

$$S = \begin{cases} W & 0 < z < L - \delta \\ \frac{W}{\delta} (L - z) & L - \delta < z < L \end{cases}$$

The expression for  $S$  can now be substituted into (1) to give (for  $L - \delta < z < L$ )

$$M = \int S dz = \int \frac{W}{\delta} (L - z) dz = \frac{W}{\delta} \left[ Lz - \frac{z^2}{2} \right] + C$$

When  $z = L$ ,  $M = 0$  so

$$0 = \frac{W}{\delta} \left[ L^2 - \frac{L^2}{2} \right] + C = \frac{W L^2}{\delta} \frac{1}{2} + C \quad \text{so} \quad C = -\frac{W L^2}{2\delta}$$

and

$$M = \frac{W}{\delta} \left[ Lz - \frac{z^2}{2} \right] - \frac{W L^2}{2\delta} = -\frac{W}{2\delta} (L - z)^2$$

At  $z = L - \delta$ ,

$$M = -\frac{W}{2\delta} (L - (L - \delta))^2 = -\frac{W\delta}{2}$$

For the part of the beam given by  $0 < z < L - \delta$ , (1) gives

$$M = \int S dz = \int W dz = Wz + C_1$$

At  $z = L - \delta$ ,  $M$  must equal  $-\frac{W\delta}{2}$  (to equal that given by the previous calculation) so

$$W(L - \delta) + C_1 = -\frac{W\delta}{2} \quad \text{implying} \quad C_1 = -\frac{W\delta}{2} - W(L - \delta) = \frac{W\delta}{2} - WL$$

Hence  $M = Wz + \frac{W\delta}{2} - WL = W(z - L + \frac{\delta}{2})$  and so over the entire beam:

$$M = \begin{cases} W(z - L + \frac{\delta}{2}) & 0 < z < L - \delta \\ -\frac{W}{2\delta} (L - z)^2 & L - \delta < z < L \end{cases}$$

As  $\delta$  is assumed to be small i.e. close to zero, the part  $0 < z < L - \delta$  becomes the part  $0 < z < L$  i.e. the whole beam and therefore:

$$S = W \quad \text{and} \quad M = W\left(z - L + \frac{\delta}{2}\right)$$

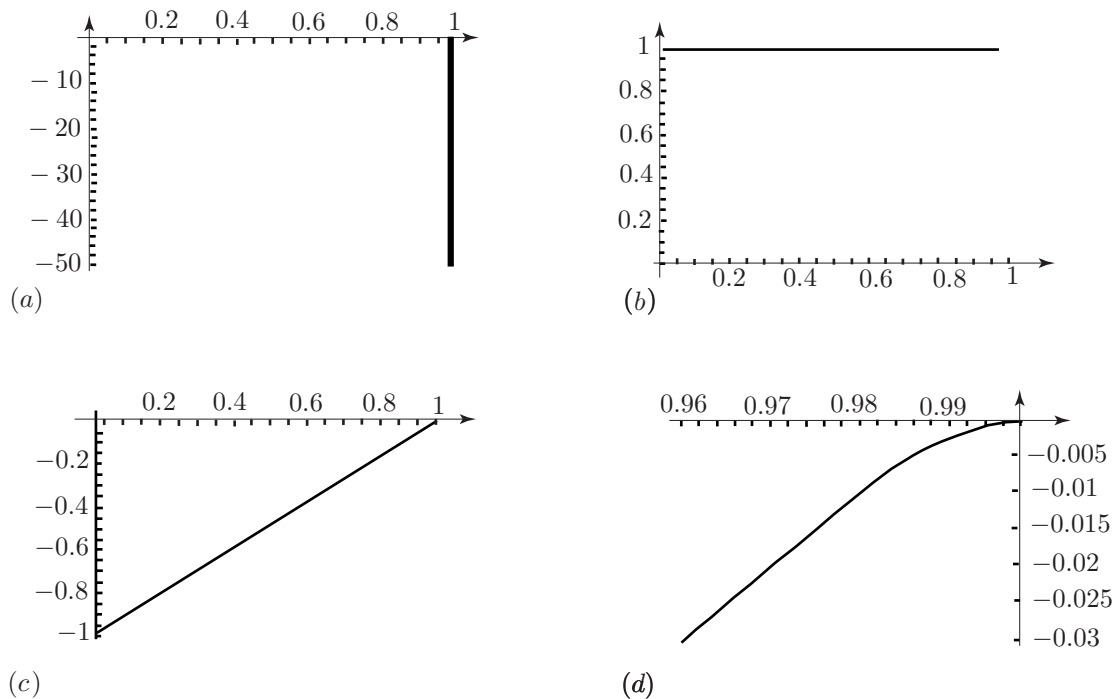

**Figure 5.2:** The load (a), shear force (b) and bending moment (c) (plus magnified portion (d))

### Interpretation

It is worth noting that a concentrated load of  $W$  causes a change in the shear force of  $W$ .

### Mathematical comment

Here the concentrated load was modelled with a distributed force. This presents a few mathematical problems. Mathematically it might be better to model the concentrated load with a delta function. In order to do this one needs a knowledge of delta functions which is outside our present scope.

## Deflection of a beam

### Mathematical Skills

Topic	Workbook
Integration	[13]
Fourth order ODEs	[19]
Laplace transforms	[20]

### Introduction

A uniformly loaded beam of length  $L$  is supported at both ends as shown in Figure 1. The deflection  $y(x)$  is a function of horizontal position  $x$  and obeys the ordinary differential equation (ODE)

$$\frac{d^4 y(x)}{dx^4} = \frac{1}{EI} q(x) \quad (1)$$

where  $E$  is Young's modulus,  $I$  is the moment of inertia and  $q(x)$  is the load per unit length at point  $x$ . We assume in this problem that  $q(x) = q$  (a constant).

The boundary conditions are

- (a) no deflection at  $x = 0$  and  $x = L$
- (b) no curvature of the beam at  $x = 0$  and  $x = L$ .

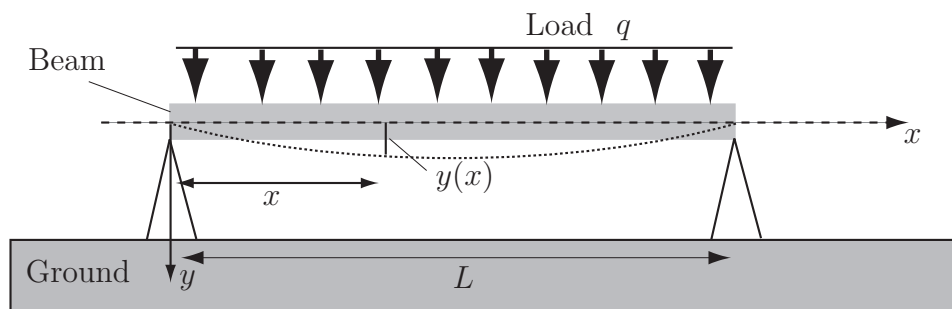

**Figure 6.1:** The deflected beam and parameters involved in the mathematical formulation

### Problem in words

Find the deflection of a beam, supported so that there is no deflection and no curvature of the beam at its ends, subject to a uniformly distributed load, as function of horizontal position along the beam.

### Mathematical statement of problem

Find the equation of the curve  $y(x)$  assumed by the bending beam that solves the ODE (1). Use the coordinate system shown in Figure 6.1 where the origin is at the left extremity of the beam. In this coordinate system, the boundary conditions

- (i) that there is no deflection at  $x = 0$ ,
- (ii) there is no deflection at  $x = L$ ,
- (iii) that there is no curvature of the beam at  $x = 0$ ,
- (iv) that there is no curvature of the beam at  $x = L$ ,

may be written

$$(i) \quad y(0) = 0$$

$$(ii) \quad y(L) = 0$$

$$(iii) \quad \left. \frac{d^2 y}{dx^2} \right|_{x=0}$$

$$(iv) \quad \left. \frac{d^2 y}{dx^2} \right|_{x=L} = 0$$

Note that  $\frac{dy(x)}{dx}$  and  $\frac{d^2 y(x)}{dx^2}$  are respectively the slope and, provided the deflection is small, the radius of curvature of the curve at point  $(x, y)$ .

### Mathematical analysis

There are two methods of proceeding:

- I. Integration of the ODE (done here on pages 22-23 and in HELM 19, pages 67-68).
- II. Laplace transform of the ODE (done here on pages 24-25 and in HELM 20, pages 50-52).

### Solution by integration of the ODE

Solving the ODE by the method of integration requires a four-fold integration of Equation (1) and the use of the boundary conditions (i) - (iv) to determine the constants of integration involved.

Integrating Equation (1) once

$$EI \frac{d^3 y(x)}{dx^3} = qx + A \quad (2)$$

Integrating a second time

$$EI \frac{d^2 y(x)}{dx^2} = qx^2/2 + Ax + B \quad (3)$$

Integrating a third time

$$EI \frac{dy(x)}{dx} = qx^3/6 + Ax^2/2 + Bx + C \quad (4)$$

Integrating a fourth time

$$EI y(x) = qx^4/24 + Ax^3/6 + Bx^2/2 + Cx + D. \quad (5)$$

The boundary conditions (i)-(iv) enable determination of the constants of integration  $A$ ,  $B$ ,  $C$ , and  $D$ .

In Equation (5), the first boundary condition  $y(0) = 0$  gives

$EI y(0) = q \times (0)^4/24 + A \times (0)^3/6 + B \times (0)^2/2 + C \times (0) + D = 0$  which implies

$$D = 0 \quad (6)$$

Using the second boundary condition  $y(L) = 0$  in Equation (5) gives

$$EI y(L) = qL^4/24 + AL^3/6 + BL^2/2 + CL + D.$$

Hence, since  $D = 0$  from (6):

$$qL^4/24 + AL^3/6 + BL^2/2 + CL = 0 \quad (7)$$

Using the third boundary condition  $\left. \frac{d^2 y}{dx^2} \right|_{x=0} = 0$  in Equation (3) gives

$$EI \left. \frac{d^2 y}{dx^2} \right|_{x=0} = q \times (0)^2/2 + A \times (0) + B$$

which implies that

$$B = 0. \quad (8)$$

Using the fourth boundary condition  $\left. \frac{d^2 y}{dx^2} \right|_{x=L} = 0$  in Equation (3) gives

$$EI \left. \frac{d^2 y}{dx^2} \right|_{x=L} = qL^2/2 + AL = 0$$

which implies

$$A = -qL/2 \quad (9)$$

The expressions for  $A$  and  $B$  in (8) and (9) are substituted in Equation (6) to find the last unknown constant  $C$ .

Hence  $qL^4/24 - qL^4/12 + CL = 0$  so

$$C = qL^3/24 \quad (10)$$

Finally, Equation (5) and the values of the four constants from (6), (8), (9), (10) lead to the solution

$$y(x) = \frac{1}{EI} [qx^4/24 - qLx^3/12 + qL^3x/24] \quad (11)$$

### Interpretation

The predicted deflection is zero at both ends which is a check that the end conditions have been applied correctly. It is possible to check that it is symmetrical about the centre of the beam by using the coordinate system  $(X, Y)$  with  $L/2 - x = X$  and  $y = Y$  and verifying that the deflection  $Y(X)$  is symmetrical about the vertical axis i.e.  $Y(X) = Y(-X)$ .

### Solution by Laplace transform

The following Laplace transform properties are needed:

$$\mathcal{L} \left\{ \frac{d^n f(t)}{dt^n} \right\} = \sum_{k=1}^n s^{k-1} \frac{d^{n-k} f}{dx^{n-k}} \Big|_{x=0} \quad (P1)$$

$$\mathcal{L} \{1\} = 1/s \quad (P2)$$

$$\mathcal{L} \{t^n\} = n!/s^{n+1} \quad (P3)$$

$$\mathcal{L}^{-1} \{ \mathcal{L} \{f(t)\} \} = f(t) \quad (P4)$$

To solve a differential equation involving the unknown function  $f(t)$  using Laplace transforms the procedure is:

- Write the Laplace transform of the differential equation using property (P1)
- Solve for the function  $\mathcal{L} \{f(t)\}$  using properties (P2) and (P3)
- Use the inverse Laplace transform to obtain  $f(t)$  using property (P4)

Using the linearity properties of the Laplace transform, (1) becomes

$$\mathcal{L} \left\{ \frac{d^4 y}{dx^4}(x) \right\} - \mathcal{L} \left\{ \frac{q}{EI} \right\} = 0.$$

Using (P2) and (P3)

$$s^4 \mathcal{L} \{y(x)\} - \sum_{k=1}^4 s^{k-1} \frac{d^{4-k} y}{dx^{4-k}} \Big|_{x=0} - \frac{q}{EI} \frac{1}{s} = 0. \quad (2)$$

The four terms of the sum are

$$\sum_{k=1}^4 s^{k-1} \frac{d^{4-k} y}{dx^{4-k}} \Big|_{x=0} = \frac{d^3 y}{dx^3} \Big|_{x=0} + d \frac{d^2 y}{dx^2} \Big|_{x=0} + s^2 \frac{dy}{dx} \Big|_{x=0} + s^3 y(0).$$

The boundary conditions give  $y(0) = 0$  and  $\frac{d^2 y}{dx^2} = 0$ , so (2) becomes

$$s^4 \mathcal{L}\{y(x)\} - \frac{d^3 y}{dx^3} \Big|_{x=0} - s^2 \frac{dy}{dx} \Big|_{x=0} - \frac{q}{EI} \frac{1}{s} = 0. \quad (3)$$

Here  $\frac{d^3 y}{dx^3} \Big|_{x=0}$  and  $\frac{dy}{dx} \Big|_{x=0}$  are unknown *constants*, but they can be determined by using the remaining two boundary conditions  $y(L) = 0$  and  $\frac{d^2 y}{dx^2} \Big|_{x=L} = 0$ .

Solving for  $\mathcal{L}\{y(x)\}$ , (3) leads to

$$\mathcal{L}\{y(x)\} = \frac{1}{s^4} \frac{d^3 y}{dx^3} \Big|_{x=0} + \frac{1}{s^2} \frac{dy}{dx} \Big|_{x=0} + \frac{q}{EI} \frac{1}{s^5}.$$

Using the linearity of the Laplace transform, the inverse Laplace transform of this equation gives

$$\mathcal{L}^{-1}\{\mathcal{L}\{y(x)\}\} = \frac{d^3 y}{dx^3} \Big|_{x=0} \times \mathcal{L}^{-1}\left\{\frac{1}{s^4}\right\} + \frac{dy}{dx} \Big|_{x=0} \times \mathcal{L}^{-1}\left\{\frac{1}{s^2}\right\} + \frac{q}{EI} \mathcal{L}^{-1}\left\{\frac{1}{s^5}\right\}.$$

Hence

$$y(x) = \frac{d^3 y}{dx^3} \Big|_{x=0} \times \mathcal{L}^{-1}\left\{3! \frac{1}{s^4}\right\} / 3! + \frac{dy}{dx} \Big|_{x=0} \times \mathcal{L}^{-1}\left\{\frac{1}{s^2}\right\} + \frac{q}{EI} \mathcal{L}^{-1}\left\{4! \frac{1}{s^5}\right\} / 4!$$

So using (P3)

$$y(x) = \frac{d^3 y}{dx^3} \Big|_{x=0} \times \mathcal{L}^{-1}\{\mathcal{L}\{x^3\}\} / 6 + \frac{dy}{dx} \Big|_{x=0} \times \mathcal{L}^{-1}\{\mathcal{L}\{x^1\}\} + \frac{q}{EI} \mathcal{L}^{-1}\{\mathcal{L}\{x^4\}\} / 24.$$

Simplifying by means of (P4)

$$y(x) = \frac{d^3 y}{dx^3} \Big|_{x=0} \times x^3 / 6 + \frac{dy}{dx} \Big|_{x=0} \times x + \frac{q}{EI} x^4 / 24. \quad (4)$$

To use the boundary condition  $\frac{d^2 y}{dx^2} \Big|_{x=L} = 0$ , take the second derivative of (4), to obtain

$$\frac{d^2 y}{dx^2}(x) = \frac{d^3 y}{dx^3} \Big|_{x=0} \times x + \frac{q}{2EI} x^2.$$

The boundary condition  $\frac{d^2 y}{dx^2} \Big|_{x=L} = 0$  implies

$$\frac{d^3 y}{dx^3} \Big|_{x=0} = -\frac{q}{2EI} L. \quad (5)$$

Using the last boundary condition  $y(L) = 0$  with (5) in (4)

$$\frac{dy}{dx} \Big|_{x=0} = \frac{qL^3}{24EI} \quad (6)$$

Finally substituting (5) and (6) in (4) gives



$$y(x) = \frac{q}{24EI}x^4 - \frac{qL}{12EI}x^3 + \frac{qL^3}{24EI}x.$$

**Interpretation**

The predicted deflection is zero at both ends which is a check that the end conditions have been applied correctly. It is possible to check that it is symmetrical about the centre of the beam by using the coordinate system  $(X, Y)$  with  $L/2 - x = X$  and  $y = Y$  and verifying that the deflection  $Y(X)$  is symmetrical about the vertical axis i.e.  $Y(X) = Y(-X)$ .

## Buckling of columns

### Mathematical Skills

Topic	Workbook
Trigonometrical identities	[4]
Matrices and determinants	[7]
Matrix solution of equations	[8]
Integration	[13]
Fourth order ODEs	[19]

### Introduction

A vertical beam (known as a **column**), is subject to a compressive force - for instance, a pillar supporting a load, or simply its own weight. Normally, if a horizontal force is applied to the column, there will be other forces to restore it to its non-deflected position for example through the end supports. However, under particular circumstances (dependent upon the column's properties and the nature of the end supports), these other forces may not be present i.e. there may be equilibrium positions other than zero deflection.

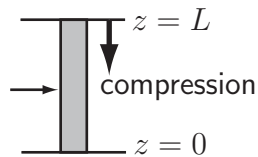

**Figure 7.1**

Their existence can be disastrous for the column. Any additional horizontal load can cause it to deflect further, and the column's ability to support its load is in doubt. Under such conditions the column may **buckle** and eventually break, thus bringing down its load (e.g. a roof). The deflection of a beam satisfies the 4th order ordinary differential equation (ODE)

$$EI \frac{d^4 w}{dx^4} - N \frac{d^2 w}{dx^2} = q$$

where

- $w$  is the deflection as a function of position  $x$
- $EI$  is the flexural rigidity
- $N$  is the tension in the beam and
- $q$  is the load perpendicular to the beam

In general, using the definition in Engineering Case Study 5 (Equation 2), the shear force is given by

$$S = - \int q dz = -EI \frac{d^3 w}{dz^3} - P \frac{dw}{dz} + \text{constant}$$

Also, from Engineering Case Study 5 (Equation 1)

$$M = \int S dz = -EI \frac{d^2 w}{dz^2} - P + \text{constant}$$

When the beam is vertical (i.e. a column), there will be no load perpendicular to the beam ( $q = 0$ ). There is an axial compressive force, denoted  $P$ , where  $P = -N$  i.e. the tension is negative. Denoting the vertical position by  $z$  with  $w = w(z)$ , the equation becomes

$$EI \frac{d^4 w}{dz^4} + P \frac{d^2 w}{dz^2} = 0$$

If this equation has only zero solutions then buckling cannot occur; however, if any other solution exists, then the column is liable to buckling. The buckling risk is also influenced by the nature of the top ( $z = L$ ) and bottom ( $z = 0$ ) supports of the column. There are three types of support:

- (a) Built-in: This means no lateral movement and no rotation.
- (b) Simply-supported: This means no translation or curvature but rotation is possible.
- (c) Free: This means that the support is free to move (translate or rotate but no curvature).

No lateral movement requires  $w = 0$ .

No rotation requires  $\frac{dw}{dz} = 0$ .

No curvature requires  $\frac{d^2 w}{dz^2} = 0$ .

There are four main possibilities:

1. **Built-in top and built-in bottom** - the top and bottom of the column are unable to move and no rotation is possible. The boundary conditions are

$$(a) \text{ At } z = 0, \quad w = 0 \quad \text{and} \quad \frac{dw}{dz} = 0$$

$$(b) \text{ At } z = L, \quad w = 0 \quad \text{and} \quad \frac{dw}{dz} = 0$$

2. **Simply-supported top and built-in bottom** - the bottom is as described in (i), while the top may rotate but no translation is possible. The boundary conditions are

$$(a) \text{ At } z = 0, \quad w = 0 \quad \text{and} \quad \frac{dw}{dz} = 0$$

$$(b) \text{ At } z = L, \quad w = 0 \quad \text{and} \quad \frac{d^2 w}{dz^2} = 0 \quad (\text{no movement and no curvature of the column})$$

3. **Free top and built-in bottom** - the bottom is as described in (i) but the top is free to move.

$$(a) \text{ At } z = 0, \quad w = 0 \quad \text{and} \quad \frac{dw}{dz} = 0$$

$$(b) \text{ At } z = L, \quad \frac{d^2 w}{dz^2} = 0 \quad \text{and} \quad -EI \frac{d^3 w}{dz^3} - P \frac{dw}{dz} = 0$$

[The conditions at  $z = L$  imply zero curvature and zero shear force respectively, (see earlier and below).]

Due to the presence of axial load  $P$  on the cross section of the beam, the resultant shear force (perpendicular to the axis of the beam before deformation) is no longer simply  $q$  any more.  $P$  makes a contribution as well. The resultant shear force is (see Figure 7.2)

$$V = q + P \frac{dw}{dx} = -EI \frac{d^3w}{dx^3} + P \frac{dw}{dx}$$

When one comes to prescribe boundary conditions, e.g., for a free-end where shear force is involved, it is vitally important that the resultant shear force  $V$  is employed instead of  $Q$ .

The free-end boundary conditions will be

$$M = -EI \frac{d^2w}{dx^2} = 0 \quad \text{and} \quad V = -EI \frac{d^3w}{dx^3} - P \frac{dw}{dx} = 0$$

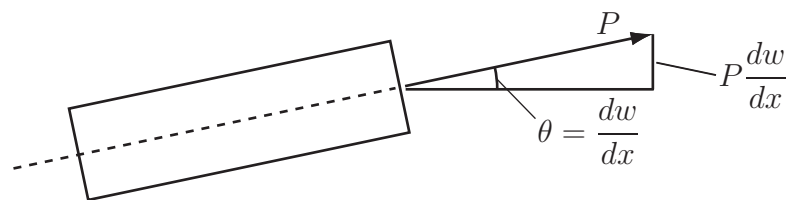

**Figure 7.2**

This scenario applies to columns supporting merely their own weight.

4. **Simply-supported** top and **simply-supported** bottom - at each end of the column, rotation is possible, but translation not. The boundary conditions are

(a) At  $z = 0$ ,  $w = 0$  and  $\frac{d^2w}{dz^2} = 0$

(b) At  $z = L$ ,  $w = 0$  and  $\frac{d^2w}{dz^2} = 0$

In each case, there are 2 boundary conditions at both the top and bottom of the column, i.e. 4 boundary conditions to enable solution of a 4th order ODE.

### Problem in words

Determine the conditions in the column (i.e.  $P$  as a function of  $E$ ,  $I$  and  $L$ ) that enable buckling in the four cases

1. built-in top and bottom
2. simply-supported top and built-in bottom
3. free top and built-in bottom
4. simply-supported top and bottom

### Mathematical statement of problem

It is necessary to solve the 4th order ODE

$$E I \frac{d^4 w}{dz^4} + P \frac{d^2 w}{dz^2} = 0 \quad (1)$$

under the four sets of boundary conditions

$$(i) \quad z = 0 \Rightarrow w = 0 \quad \text{and} \quad \frac{dw}{dz} = 0 ; \quad z = L \Rightarrow w = 0 \quad \text{and} \quad \frac{dw}{dz} = 0$$

$$(ii) \quad z = 0 \Rightarrow w = 0 \quad \text{and} \quad \frac{dw}{dz} = 0 ; \quad z = L \Rightarrow w = 0 \quad \text{and} \quad \frac{d^2 w}{dz^2} = 0$$

$$(iii) \quad z = 0 \Rightarrow w = 0 \quad \text{and} \quad \frac{dw}{dz} = 0 ; \quad z = L \Rightarrow \frac{d^2 w}{dz^2} = 0 \quad \text{and} \quad -E I \frac{d^3 w}{dz^3} - P \frac{dw}{dz} = 0$$

$$(iv) \quad z = 0 \Rightarrow w = 0 \quad \text{and} \quad \frac{d^2 w}{dz^2} = 0 ; \quad z = L \Rightarrow w = 0 \quad \text{and} \quad \frac{d^2 w}{dz^2} = 0$$

which correspond to the four sets of end supports described, and, in each case find the condition on  $P$  such that solutions other than  $w = 0$  are possible.

### Mathematical analysis

The general solution of the ODE is

$$w(z) = w_c(z) + w_p(z)$$

where  $w_c(z)$  is the **complementary function** and  $w_p(z)$  is the **particular solution**. Here,  $w_p = 0$  since the right-hand side of (1) is zero.

To find the complementary function, first substitute  $w = e^{\lambda z}$  into (1) to get

$$(E I \lambda^4 + P \lambda^2) e^{\lambda z} = 0$$

then the **characteristic equation** is

$$E I \lambda^4 + P \lambda^2 = 0$$

or

$$\lambda^2(\lambda^2 + \beta^2) = 0 \quad \text{where} \quad \beta = \sqrt{\frac{P}{E I}}$$

with roots

$$\lambda_1 = \lambda_2 = 0, \quad \lambda_3, \lambda_4 = \pm i\beta$$

so that the complementary functions are

$$A + Bz \quad \text{and} \quad C \sin(\beta z) + D \cos(\beta z)$$

giving the general solution of the ODE

$$w(z) = A + Bz + C \sin(\beta z) + D \cos(\beta z) \quad (2)$$

where  $A$ ,  $B$ ,  $C$  and  $D$  are determined by the boundary conditions.

In order to apply the boundary conditions, the following quantities will also be needed.

$$\frac{dw}{dz} = B + C\beta \cos(\beta z) - D\beta \sin(\beta z) \quad (3)$$

$$\frac{d^2 w}{dz^2} = -\beta^2 (C \sin(\beta z) + D \cos(\beta z)) \quad (4)$$

$$\frac{d^3w}{dz^3} = \beta^3 (D \sin(\beta z) - C \cos(\beta z))$$

so that, using the last and first of these and the expression  $\beta^2 = \frac{P}{EI}$ , it can be shown that

$$EI \frac{d^3w}{dz^3} + P \frac{dw}{dz} = B\beta^2 EI \quad (5)$$

Now take each case in turn.

1. **Built-in top** and **built-in bottom** - applying the boundary conditions (i) to Equations (3) and (4) gives the four linear equations

$$\begin{aligned} A + D &= 0 \\ B + \beta C &= 0 \\ A + BL + C \sin(\beta L) + D \cos(\beta L) &= 0 \\ B + C\beta \cos(\beta L) - D\beta \sin(\beta L) &= 0 \end{aligned}$$

which are written in matrix form as

$$M \begin{bmatrix} A \\ B \\ C \\ D \end{bmatrix} = 0$$

where  $M$  is the matrix

$$\begin{bmatrix} 1 & 0 & 0 & 1 \\ 0 & 1 & \beta & 0 \\ 1 & L & \sin(\beta L) & \cos(\beta L) \\ 0 & 1 & \beta \cos(\beta L) & -\beta \sin(\beta L) \end{bmatrix}$$

Clearly  $A = B = C = D = 0$  is a solution to (7) and in the case where  $M$  is an invertible matrix, this is the only solution. However, this gives  $w = 0$  so that the only equilibrium is the case of no deflection. If, however,  $M$  is a singular matrix, there will be an infinite number of solutions to (7). Thus, buckling may occur when the determinant of  $M$  is zero. Expressing  $s = \sin(\beta L)$  and  $c = \cos(\beta L)$

$$\begin{aligned} \det M = |M| &= \begin{vmatrix} 1 & 0 & 0 & 1 \\ 0 & 1 & \beta & 0 \\ 1 & L & s & c \\ 0 & 1 & \beta c & -\beta s \end{vmatrix} \\ &= \begin{vmatrix} 1 & \beta & 0 \\ L & s & c \\ 1 & \beta c & -\beta s \end{vmatrix} - \begin{vmatrix} 0 & 1 & \beta \\ 1 & L & s \\ 0 & 1 & \beta c \end{vmatrix} \\ &= \begin{vmatrix} s & c \\ \beta c & -\beta s \end{vmatrix} - \beta \begin{vmatrix} L & c \\ 1 & -\beta s \end{vmatrix} + \begin{vmatrix} 1 & s \\ 0 & \beta c \end{vmatrix} - \beta \begin{vmatrix} 1 & L \\ 0 & 1 \end{vmatrix} \\ &= -\beta s^2 - \beta c^2 + \beta^2 Ls + \beta c + \beta c - \beta \\ &= \beta(\beta Ls + 2c - 2) \quad \text{since} \quad \sin^2(\beta L) + \cos^2(\beta L) = 1 \end{aligned}$$

leading to the following condition for a non-trivial (non-zero) solution

$$\beta L \sin(\beta L) + 2 \cos(\beta L) - 2 = 0 \quad (6)$$

Using the trigonometrical identities  $\sin 2\theta \equiv 2 \sin \theta \cos \theta$  and  $1 - \cos 2\theta \equiv 2 \sin^2 \theta$  Equation (6) can be written as

$$4 \sin\left(\frac{\beta L}{2}\right) \left[ \frac{\beta L}{2} \cos\left(\frac{\beta L}{2}\right) - \sin\left(\frac{\beta L}{2}\right) \right] = 0$$

so that either

$$\sin\left(\frac{\beta L}{2}\right) = 0 \quad (7)$$

or

$$\frac{\beta L}{2} \cos\left(\frac{\beta L}{2}\right) - \sin\left(\frac{\beta L}{2}\right) = 0 \quad (8)$$

Solutions for (7) are  $\beta L = 2n\pi$ ,  $n = 1, 2, 3, \dots$  giving

$$P = 4n^2\pi^2 \frac{EI}{L^2} \quad n = 1, 2, 3, \dots \quad (9)$$

the smallest of which ( $n = 1$ ) is  $4\pi^2 EI/L^2 \simeq 39.5EI/L^2$ .

Equation (8) may be expressed as  $\frac{\beta L}{2} \cot\left(\frac{\beta L}{2}\right) = 1$ . The first solution of (8) is  $40.38EI/L^2$  which is larger.

As the load  $P$  increases from zero, it is the first value at which it will buckle which is of interest. This **critical value** is therefore found from (9) with  $n = 1$  to be

$$P_{cr} = 4\pi^2 \frac{EI}{L^2} \simeq 39.5 \frac{EI}{L^2}$$

2. **Simply-supported top and built-in bottom** - applying the boundary conditions (ii) to Equations (3), (4) and (5) gives the four linear equations

$$\begin{aligned} A + D &= 0 \\ B + \beta C &= 0 \\ A + BL + C \sin(\beta L) + D \cos(\beta L) &= 0 \\ C \sin(\beta L) + D \cos(\beta L) &= 0 \end{aligned}$$

with coefficient matrix

$$M = \begin{bmatrix} 1 & 0 & 0 & 1 \\ 0 & 1 & \beta & 0 \\ 1 & L & \sin(\beta L) & \cos(\beta L) \\ 0 & 0 & \sin(\beta L) & \cos(\beta L) \end{bmatrix}$$

and determinant (noting the expansion along the top row and the use of properties of

determinants in the left-hand 3 by 3 determinant)

$$\begin{aligned}
 \det M &= \begin{vmatrix} 1 & 0 & 0 & 1 \\ 0 & 1 & \beta & 0 \\ 1 & L & \sin(\beta L) & \cos(\beta L) \\ 0 & 0 & \sin(\beta L) & \cos(\beta L) \end{vmatrix} \\
 &= \begin{vmatrix} 1 & \beta & 0 \\ L & \sin(\beta L) & \cos(\beta L) \\ 0 & \sin(\beta L) & \cos(\beta L) \end{vmatrix} - \begin{vmatrix} 0 & 1 & \beta \\ 1 & L & \sin(\beta L) \\ 0 & 0 & \sin(\beta L) \end{vmatrix} \\
 &= \begin{vmatrix} 1 & \beta & 0 \\ L & 0 & 0 \\ 0 & \sin(\beta L) & \cos(\beta L) \end{vmatrix} - \sin(\beta L) \begin{vmatrix} 0 & 1 \\ 1 & L \end{vmatrix} \\
 &= -\beta L \cos(\beta L) + \sin(\beta L)
 \end{aligned}$$

leading to the condition for a non-zero solution

$$\beta L = \tan(\beta L)$$

with first solution  $\beta L = 4.49$ , so that

$$P_{cr} = (4.49)^2 \frac{EI}{L^2} \simeq 20.2 \frac{EI}{L^2}$$

3. **Free top and built-in bottom** - applying the boundary conditions (iii) to Equations (3), (4), (5) and (6) gives the four linear equations

$$\begin{aligned}
 A + D &= 0 \\
 B + \beta C &= 0 \\
 C \sin(\beta L) + D \cos(\beta L) &= 0 \\
 B &= 0
 \end{aligned}$$

with coefficient matrix

$$M = \begin{bmatrix} 1 & 0 & 0 & 1 \\ 0 & 1 & \beta & 0 \\ 0 & 0 & \sin(\beta L) & \cos(\beta L) \\ 0 & 1 & 0 & 0 \end{bmatrix}$$

and determinant (found by expanding down the left column and then along the bottom row)

$$\begin{aligned}
 \det M &= \begin{vmatrix} 1 & 0 & 0 & 1 \\ 0 & 1 & \beta & 0 \\ 0 & 0 & \sin(\beta L) & \cos(\beta L) \\ 0 & 1 & 0 & 0 \end{vmatrix} \\
 &= \begin{vmatrix} 1 & \beta & 0 \\ 0 & \sin(\beta L) & \cos(\beta L) \\ 1 & 0 & 0 \end{vmatrix} = \begin{vmatrix} \beta & 0 \\ \sin(\beta L) & \cos(\beta L) \end{vmatrix} \\
 &= \beta \cos(\beta L)
 \end{aligned}$$

leading to the condition for a non-zero solution



$$\cos(\beta L) = 0$$

with general solution

$$\beta L = \frac{(2n-1)}{2}\pi \quad n = 1, 2, 3, \dots$$

the smallest solution of which is for  $n = 1$ , i.e.

$$P_{cr} = \frac{\pi^2 EI}{4 L^2} \simeq 2.5 \frac{EI}{L^2}$$

4. **Simply-supported top** and **simply-supported bottom** - applying the boundary conditions (iv) to Equations (3) and (5) gives the four linear equations

$$A + D = 0$$

$$D = 0$$

$$A + BL + C \sin(\beta L) + D \cos(\beta L) = 0$$

$$C \sin(\beta L) + D \cos(\beta L) = 0$$

with coefficient matrix

$$M = \begin{bmatrix} 1 & 0 & 0 & 1 \\ 0 & 0 & 0 & 1 \\ 1 & L & \sin(\beta L) & \cos(\beta L) \\ 0 & 0 & \sin(\beta L) & \cos(\beta L) \end{bmatrix}$$

and determinant (found by expanding along the second row and then along the top row)

$$\begin{aligned} \det M &= \begin{vmatrix} 1 & 0 & 0 & 1 \\ 0 & 0 & 0 & 1 \\ 1 & L & \sin(\beta L) & \cos(\beta L) \\ 0 & 0 & \sin(\beta L) & \cos(\beta L) \end{vmatrix} \\ &= \begin{vmatrix} 1 & 0 & 0 \\ 1 & L & \sin(\beta L) \\ 0 & 0 & \sin(\beta L) \end{vmatrix} = \begin{vmatrix} L & \sin(\beta L) \\ 0 & \sin(\beta L) \end{vmatrix} \\ &= L \sin(\beta L) \end{aligned}$$

leading to the condition for a non-zero solution

$$\sin(\beta L) = 0$$

with general solution

$$\beta L = n\pi \quad n = 1, 2, 3, \dots$$

the smallest solution of which is for  $n=1$ , i.e.

$$P_{cr} = \pi^2 \frac{EI}{L^2} \simeq 9.9 \frac{EI}{L^2}$$

## Interpretation

A column is subject to buckling if the compressive force  $P$  is equal to one of several critical values. For each type of end support, the first critical value is given below.

top support	bottom support	first critical load
free	built-in	$P_{cr} = 2.5 \frac{EI}{L^2}$
simply-supported	simply-supported	$P_{cr} = 9.9 \frac{EI}{L^2}$
simply-supported	built-in	$P_{cr} = 20.2 \frac{EI}{L^2}$
built-in	built-in	$P_{cr} = 39.5 \frac{EI}{L^2}$

For a given column, the first critical value can be increased by increasing the value of the ratio  $\frac{EI}{L^2}$  (in practice, increasing  $EI$  rather than decreasing  $L$  as the column presumably still has to reach to the roof etc). However, a more effective strategy may well be to ensure built-in supports for the column at each end which can increase the first critical value by a factor of approximately 2, 4 or 16 depending on the original type of support used.



# Engineering Case Study 8

## Maximum bending moment for a multiple structure

### Mathematical Skills

Topic	Workbook
Maxima and Minima	[12]

### Introduction

The ability to model the effects of moving loads on a structure is important, for example in bridge design. Engineering Case Study 5 has introduced the definition of **bending moment** and its relationship to **shear force**. The bending moment is a measure of the tendency for a beam to bend and is a function of both the position of the load and the position of the point where the bending moment is being measured.

Imagine that a load of weight  $W$  moves on to a beam  $OP$  of length  $L$  and that the bending moment is measured at point  $A$ , which is a distance  $a$  from the left end of the beam (See Figure 8.1). When the load is at a distance  $z$  from  $O$ , the left end of the beam, then the bending moment is (proportional to)

$$M = W \begin{cases} \frac{L-a}{L} z & z < a \\ \frac{L-z}{L} a & z > a \end{cases} \quad (1)$$

which has derivative

$$\frac{dM}{dz} = W \begin{cases} \frac{L-a}{L} (> 0) & z < a \\ -\frac{a}{L} (< 0) & z > a \end{cases}$$

A graph of the variation of  $M$  with position  $z$  along the beam is shown in Figure 8.1.

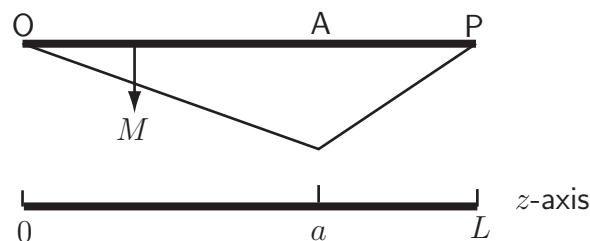

**Figure 8.1:** Variation of bending moment measured at a particular point with position of a load along the beam

The bending moment measure at  $A$  starts from a value of zero as the weight moves onto the beam at  $O$ , increases at a constant rate as the weight approaches  $A$ , reaches a maximum as the weight passes over  $A$  and then decreases linearly to zero as the weight moves further to the other end of the beam at  $P$ . By convention, since positive  $M$  represents a sagging beam, it is shown downwards

in Figure 8.1. Nevertheless, the bending moment is at a **maximum** when the weight passes over the point where it is being measured.

Often, rather than acting at a single point, a load acts at several point which remain a fixed distance apart e.g. a truck, a person cycling, a table standing on four legs, or railway wagons coupled together. Finding the point at which the maximum bending moment occurs can be done in a similar manner to that illustrated above.

### Problem in words

A 'train' consists of three wagons with weights of 6 kN, 2 kN and 5 kN respectively. Each wagon is separated from its neighbour by a constant distance of 1 m. It moves onto and crosses a beam of length 20 m. If the bending moment is measure at a point 13 m from the end where the weights pass onto the beam, find the position of the 'train' that produces the largest bending moment.

What measuring location would correspond to the maximum bending moment as each wagon passes over it?

### Mathematical statement of problem

(a) Construct a function

$$M = \sum_{i=1}^3 W_i \begin{cases} \frac{(L-a)}{L} z_i & z_i < a \\ \frac{(L-z_i)}{L} a & z_i > a \end{cases} \quad (2)$$

for the total bending moment measured at a distance  $a$  from the onset of the load, given that  $W_1 = 6$ ,  $W_2 = 2$ ,  $W_3 = 5$ ,  $L = 20$  and  $a = 13$ .

(b) By differentiation, find the point at which this function is a maximum.

(c) Repeat the analysis but for a general point  $a$  and consider the beam in four zones:

- zone [1]:  $2 < z_1 < a$  (before the weights pass  $a$ )
- zone [2]:  $a < z_1 < a + 1$  (only the 6 kN weight has passed  $a$ )
- zone [3]:  $a + 1 < z_1 < a + 2$  (the 6 kN and 2 kN weights have passed  $a$ )
- zone [4]:  $a + 2 < z_1 < 20$  (all three weights have passed  $a$ )

Calculate  $M$  in each of the zones, and then, by differentiation, find the range of  $a$  for which a maximum bending moment is produced when the first weight (6 kN) passes over the measurement point. Repeat this process for the second weight (2 kN) and the third weight (5 kN).

### Mathematical analysis

(a) Denote the position of the 6 kN weight by  $z_1$  and the positions of the 2 kN and 5 kN weights by  $z_2 (= z_1 - 1)$  and  $z_3 (= z_1 - 2)$  respectively.

From (2) the moment due to weight  $i$  is

$$M_i = W_i \begin{cases} \frac{7}{20} z_i & z_i < 13 \\ \frac{13}{20} (20 - z_i) & z_i > 13 \end{cases}$$

so that

$$M_1 = 6 \begin{cases} \frac{7}{20} z_1 & z_1 < 13 \\ \frac{13}{20} (20 - z_1) & z_1 > 13 \end{cases} = \begin{cases} 6 \times \frac{7}{20} z_1 & z_1 < 13 \\ 6 \times \frac{13}{20} (20 - z_1) & z_1 > 13 \end{cases}$$

$$M_2 = 2 \begin{cases} \frac{7}{20} z_2 & z_2 < 13 \\ \frac{13}{20} (20 - z_2) & z_2 > 13 \end{cases} = \begin{cases} 2 \times \frac{7}{20} (z_1 - 1) & z_1 < 14 \\ 2 \times \frac{13}{20} (21 - z_1) & z_1 > 14 \end{cases}$$

$$M_3 = 5 \begin{cases} \frac{7}{20} z_3 & z_3 < 13 \\ \frac{13}{20} (20 - z_3) & z_3 > 13 \end{cases} = \begin{cases} 5 \times \frac{7}{20} (z_1 - 2) & z_1 < 15 \\ 5 \times \frac{13}{20} (22 - z_1) & z_1 > 15 \end{cases}$$

With all three wagons on the beam (i.e.  $2 < z_1 < 20$ ), the total moment is

$$M = \begin{cases} (6 \times \frac{7}{20} z_1) + (2 \times \frac{7}{20} (z_1 - 1)) + (5 \times \frac{7}{20} (z_1 - 2)) & 2 < z_1 < 13 \\ (6 \times \frac{13}{20} (20 - z_1)) + (2 \times \frac{7}{20} (z_1 - 1)) + (5 \times \frac{7}{20} (z_1 - 2)) & 13 < z_1 < 14 \\ (6 \times \frac{13}{20} (20 - z_1)) + (2 \times \frac{13}{20} (21 - z_1)) + (5 \times \frac{7}{20} (z_1 - 2)) & 14 < z_1 < 15 \\ (6 \times \frac{13}{20} (20 - z_1)) + (2 \times \frac{13}{20} (21 - z_1)) + (5 \times \frac{13}{20} (22 - z_1)) & 15 < z_1 < 20 \end{cases}$$

$$= \begin{cases} \frac{91z_1 - 84}{20} & 2 < z_1 < 13 \\ \frac{-29z_1 + 1476}{20} & 13 < z_1 < 14 \\ \frac{-69z_1 + 2036}{20} & 14 < z_1 < 15 \\ \frac{-169z_1 + 3536}{20} & 15 < z_1 < 20 \end{cases}$$

(b) Thus

$$\frac{dM}{dz_1} = \begin{cases} 91/20 \quad (> 0) & 2 < z_1 < 13 \\ -29/20 \quad (< 0) & 13 < z_1 < 14 \\ -69/20 \quad (< 0) & 14 < z_1 < 15 \\ -169/20 \quad (< 0) & 15 < z_1 < 20 \end{cases}$$

Thus,  $M$  is an **increasing** function of  $z_1$  for  $z_1 < 13$ , but a **decreasing** function for  $z_1 > 13$  and so has a **maximum** at  $z_1 = 13$ .

The resulting variation of  $M$  with position is shown in Figure 8.2 for the period during which all three wagons are on the beam.

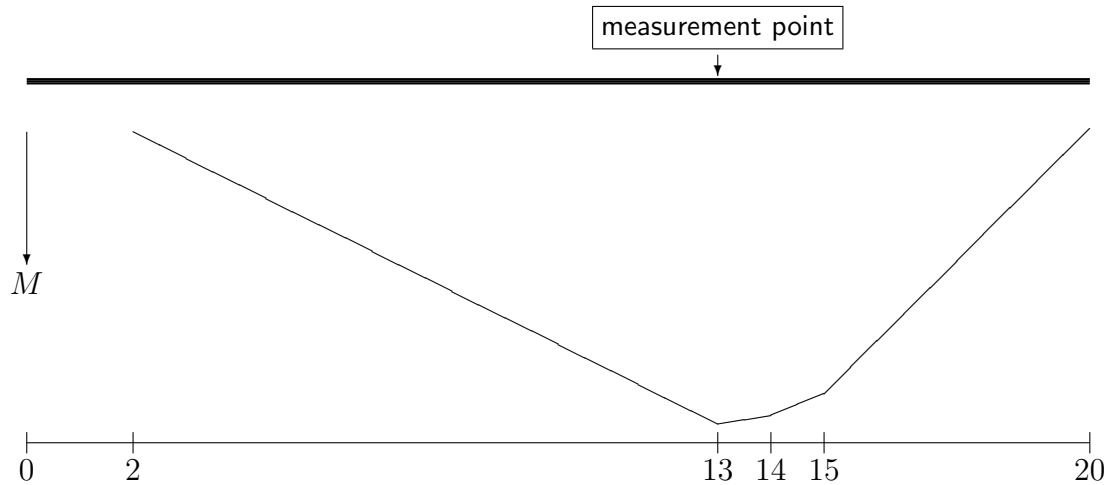

**Figure 8.2:** Variation of  $M$  with position of the 'train' when all of it is on the beam

(c) As before, an expression for the bending moment in each zone of the beam can be found.

$$M = \begin{cases} 6 \frac{(20-a)}{20} z_1 + 2 \frac{(20-a)}{20} (z_1 - 1) + 5 \frac{(20-a)}{20} (z_1 - 2) & 2 < z_1 < a \\ 6 \frac{(20-z_1)}{20} a + 2 \frac{(20-a)}{20} (z_1 - 1) + 5 \frac{(20-a)}{20} (z_1 - 2) & a < z_1 < a + 1 \\ 6 \frac{(20-z_1)}{20} a + 2 \frac{(21-z_1)}{20} a + 5 \frac{(20-a)}{20} (z_1 - 2) & a + 1 < z_1 < a + 2 \\ 6 \frac{(20-z_1)}{20} a + 2 \frac{(21-z_1)}{20} a + 5 \frac{(22-z_1)}{20} a & a + 2 < z_1 < 20 \end{cases}$$

$$= \begin{cases} \frac{z_1}{20} (260 - 13a) + \frac{1}{20} (12a - 240) & 2 < z_1 < a \\ \frac{z_1}{20} (140 - 13a) + \frac{1}{20} (132a - 240) & a < z_1 < a + 1 \\ \frac{z_1}{20} (100 - 13a) + \frac{1}{20} (172a - 200) & a + 1 < z_1 < a + 2 \\ -\frac{13az_1}{20} + \frac{272a}{20} & a + 2 < z_1 < 20 \end{cases}$$

Differentiating with respect to  $z_1$  in each zone gives

$$\begin{aligned}
 \text{zone [1] : } 2 < z_1 < a & \quad \frac{dM}{dz_1} = \frac{1}{20} (260 - 13a) > 0 \text{ for all valid } a \\
 \text{zone [2] : } a < z_1 < a + 1 & \quad \frac{dM}{dz_1} = \frac{1}{20} (140 - 13a) \begin{cases} > 0 \text{ for } a < 140/13 \\ < 0 \text{ for } a > 140/13 \end{cases} (\approx 10.8) \\
 \text{zone [3] : } a + 1 < z_1 < a + 2 & \quad \frac{dM}{dz_1} = \frac{1}{20} (100 - 13a) \begin{cases} > 0 \text{ for } a < 100/13 \\ < 0 \text{ for } a > 100/13 \end{cases} (\approx 7.7) \\
 \text{zone [4] : } a + 2 < z_1 < 20 & \quad \frac{dM}{dz_1} = -\frac{13a}{20} < 0 \text{ for all valid } a
 \end{aligned}$$

A maximum value of  $M$  is created if the derivative above changes from a positive to a negative value. Comparing the behaviour of  $\frac{dM}{dz_1}$  in adjacent zones will show the influence of each of the weights passing over  $a$ .

- Comparing the first and second zones (i.e. upon passage of the 6 kN weight), the derivative changes from positive to negative for  $a > 10.8$ .
- However, if  $a < 10.8$ , the derivative remains positive in zones [1] and [2], but becomes negative in zone [3] (i.e. upon passage of the 2 kN weight) if, additionally,  $a > 7.7$ .
- If  $a < 7.7$ , the derivative remains positive in zones [1], [2] and [3], but becomes negative in zone [4] (i.e. upon passage of the 5 kN weight).

### Interpretation and comment

In the part of the problem where  $a = 13$ , the moment at the point of measurement is greatest for  $z_1 = 13$ , i.e. as the 6 kN weight passes over it. Intuitively, it may seem obvious that the greatest bending moment should occur at the instant of passage of the largest weight, but this is not always the case, as we illustrate below.

Moreover, another way of looking intuitively at the problem, i.e. by considering the centre of mass, gives an incorrect answer. The centre of mass of the system will lie between the 6 kN and 2 kN weights. When the maximum bending moment occurs, the centre of mass is still approaching the point of measurement.

Now consider the results from the part of the problem involving arbitrary  $a$ .

- For  $a > 10.8$  the maximum bending moment occurs upon passage of the first and largest weight.
- For  $7.7 < a < 10.8$  the maximum bending moment occurs upon passage of the smallest component of the load, but the one which determines whether or not more than half the total weight has passed.
- For  $a < 7.7$  the maximum bending moment occurs upon passage of the final weight.

## Equation of the curve of a cable fixed at two end points

### Mathematical Skills

Topic	Workbook
Trigonometric identities	[4]
Hyperbolic functions	[6]
Differentiation	[11]
Integration	[13]
Length of curve (integration)	[14]

### Introduction

Cables are common components of structures. Long cables are found in suspension bridges and form overhead power lines strung between pylons. The shape and the associated tension in an overhead power cable is important, for example, when assessing its durability and the clearance it requires.

### Problem in words

Find a general equation describing the curve of a cable fixed at two endpoints at the same height above the ground. The line density of the cable is a constant,  $\rho$ , and there is no load on the cable apart from its own weight.

### Mathematical statement of the problem

We can draw a diagram of the cable as in Figure 9.1 where  $A$  and  $B$  are the end points.

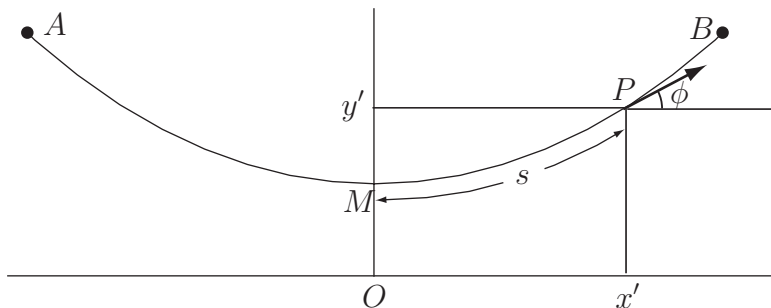

**Figure 9.1. A cable fixed at two endpoints at the same height above the ground.**

We have marked the tension,  $T$ , operating at a point,  $P$ , on the cable along a tangent to the cable. The point  $P$  is at a distance  $s$  along the cable from its midpoint and at a height  $y'$  and horizontal distance  $x'$ . If we consider a short section of the cable,  $MP$ , then the total force due to gravity operating on this section is  $s\rho g$ , operating vertically downwards. The tension at point  $P$  will have a vertical component  $T \sin(\phi)$ . The forces operating in the horizontal direction are  $T_0$  operating at the point  $M$  and  $T \cos(\phi)$ , the horizontal component of the tension, operating at  $P$ . As the cable is static, the forces both in the horizontal and vertical directions must sum to 0 independently.



So we have:

$$\text{in the vertical direction} \quad s\rho g = T \sin(\phi)$$

and

$$\text{in the horizontal direction} \quad T_0 = T \cos(\phi)$$

Note that a consequence of the constant horizontal tension is that the resultant tension is maximum where the vertical component is maximum. Dividing the first equation by the second we get a relationship for  $\tan(\phi)$

$$\frac{s\rho g}{T_0} = \tan(\phi) \quad (1)$$

where  $s$  is the distance along the cable from  $M$  and  $\tan(\phi)$  is the gradient of the tangent to the curve  $y = f(x)$  at the point  $P$ .

The geometrical interpretation of the derivative of the function is that it is equal to the gradient of the tangent to the curve, i.e.

$$\frac{dy}{dx} = \tan(\phi) \quad (2)$$

We found in HELM 14.4 that the length of a curve between points  $x = a$  and  $x = b$  is given by

$$s = \int_a^b \sqrt{1 + \left(\frac{dy}{dx}\right)^2} dx \quad (3)$$

Substituting for  $\tan(\phi)$  from Equation (1) into Equation (2) we get

$$\frac{dy}{dx} = \frac{s\rho g}{T_0}$$

Substituting for  $s$  from Equation (3) with  $a = 0$  and  $b = x'$  we get:

$$\frac{dy}{dx} = \frac{\rho g}{T_0} \left( \int_0^{x'} \sqrt{1 + \left(\frac{dy}{dx}\right)^2} dx \right)$$

$\rho$  is a constant - the line density of the cable,  $g$  is the acceleration due to gravity ( $\approx 9.81 \text{ m s}^{-2}$ ) and  $T_0$  is a constant representing the horizontal tension at the point  $M$ . We can replace all of these using a single constant,  $c$ , where  $c = \frac{T_0}{\rho g}$ . Since tension is force per unit area,  $c$  has dimensions of length.

The problem then becomes, find a function  $y = f(x)$  which satisfies the equation

$$\frac{dy}{dx} = \frac{1}{c} \left( \int_0^{x'} \sqrt{1 + \left(\frac{dy}{dx}\right)^2} dx \right) \quad (4)$$

## Mathematical analysis

Differentiating both sides of (4) with respect to  $x$  we get:

$$\frac{d^2y}{dx^2} = \frac{1}{c} \sqrt{1 + \left(\frac{dy}{dx}\right)^2} \quad (5)$$

We solve it by the substitution  $\frac{dy}{dx} = \sinh(u)$  and then using the identity  $\cosh^2(u) - \sinh^2(u) \equiv 1$ .

First we differentiate this substitution with respect to  $x$  to obtain  $\frac{d^2y}{dx^2} = \cosh(u) \frac{du}{dx}$ .

So Equation (5) becomes

$$\cosh(u) \frac{du}{dx} = \frac{1}{c} \sqrt{1 + (\sinh(u))^2}$$

From  $\cosh^2(u) - \sinh^2(u) \equiv 1$  we obtain  $\sqrt{1 + (\sinh(u))^2} = \cosh(u)$  so

$$\cosh(u) \frac{du}{dx} = \frac{1}{c} \cosh(u)$$

$$\text{so } \frac{du}{dx} = \frac{1}{c}.$$

As the right-hand side is a constant term we can easily integrate this with respect to  $x$  and we find that

$$u = \int \frac{1}{c} dx$$

so  $u = \frac{x}{c} + C$  where  $C$  is some constant.

We know that  $\sinh(u) = \frac{dy}{dx} = 0$  when  $x = 0$  (the gradient of the tangent is 0 at the point  $M$  which is where the cable is horizontal). So when  $x = 0$ , if  $\sinh(u) = 0$ , then  $u = 0$  giving  $C = 0$ , so

$$u = \frac{x}{c}$$

Taking the sinh of both sides of this expression and substituting  $\frac{dy}{dx} = \sinh(u)$  we get:

$$\frac{dy}{dx} = \sinh\left(\frac{x}{c}\right)$$

Integrating again with respect to  $x$  we find

$$y = \int \sinh\left(\frac{x}{c}\right) dx = c \cosh\left(\frac{x}{c}\right) + D.$$

Here  $D$  is some new constant which we can choose arbitrarily as it will not change the shape of the curve but just the height of the cable above the ground corresponding to the smallest value of  $y$ . For convenience, we could choose  $D = 0$  giving the equation of the cable as:  $y = c \cosh\left(\frac{x}{c}\right)$ . Since  $\cosh(0) = 1$ , this means that the height of the lowest point on the cable is  $c$ . If the ends of the cable are at  $\pm d$ , their heights will be at  $c \cosh\left(\frac{d}{c}\right)$ , since  $\cosh(-z) = \cosh z$ .

Alternatively, if we fix the height  $H$  of the end points of the cable and there is a fixed distance  $2d$  between them (i.e. the end points are at  $(\pm d, H)$ ), we could use the fact that one end of the cable

is at  $(d, H)$  to obtain

$$H = c \cosh\left(\frac{d}{c}\right) + D$$

to determine  $D$ , and hence write

$$y = c \cosh\left(\frac{x}{c}\right) + H - c \cosh\left(\frac{d}{c}\right).$$

The height of the lowest point on the cable is given by this equation with  $x = 0$ . Since  $\cosh(0) = 1$  this gives

$$y(0) = c + H - c \cosh\left(\frac{d}{c}\right) = H - c \left( \cosh\left(\frac{d}{c}\right) - 1 \right).$$

### Interpretation

We have shown that the equation of the cable hanging between two points at the same height and subject only to its own weight is given by

$$y = c \cosh\left(\frac{x}{c}\right)$$

where the origin is at the lowest point of the cable, and  $c = \frac{T_0}{\rho g}$  where  $\rho$  is the constant line density of the cable,  $T_0$  is the horizontal tension at the midpoint of the cable and  $g$  is the acceleration due to gravity. This curve is called a **catenary**. It is different from that of the cable of a suspension bridge, which is loaded by the bridge deck. The equation equivalent to (5) that applies to a suspension bridge cable, assuming that the weight of the cable is negligible compared to the weight of the bridge deck, is

$$\frac{d^2y}{dx^2} = \frac{1}{c}.$$

This has a solution of the form  $y = \frac{x^2}{2c} + C_1x + C_2$ , where  $C_1$  and  $C_2$  are constants, i.e. a **parabola**. The shape of the hanging cable depends upon the tension  $T_0$ . By means of 'tensioners' at the ends this can be varied. Figure 9.2 shows the results of calculations for cables made of material with density  $5000 \text{ kg m}^{-3}$  when strung between two masts 50 m high and 100 m apart and subject to two different tensions.

The lowest point on the cable with lower tension is 23.44 m high, whereas for the higher tension the lowest point is 37.49 m high.

The length  $L$  of the hanging cable with end points separated by  $2d$ , can be determined by returning to Equation (3). Hence

$$\begin{aligned} L &= \int_{-d}^d \sqrt{1 + \left(\sinh\left(\frac{x}{c}\right)\right)^2} dx \\ &= \int_{-d}^d \cosh\left(\frac{x}{c}\right) dx = \left[ c \sinh\left(\frac{x}{c}\right) \right]_{-d}^{+d} = c \left( \sinh\left(\frac{d}{c}\right) - \sinh\left(-\frac{d}{c}\right) \right) = 2c (\sinh(dc)). \end{aligned}$$

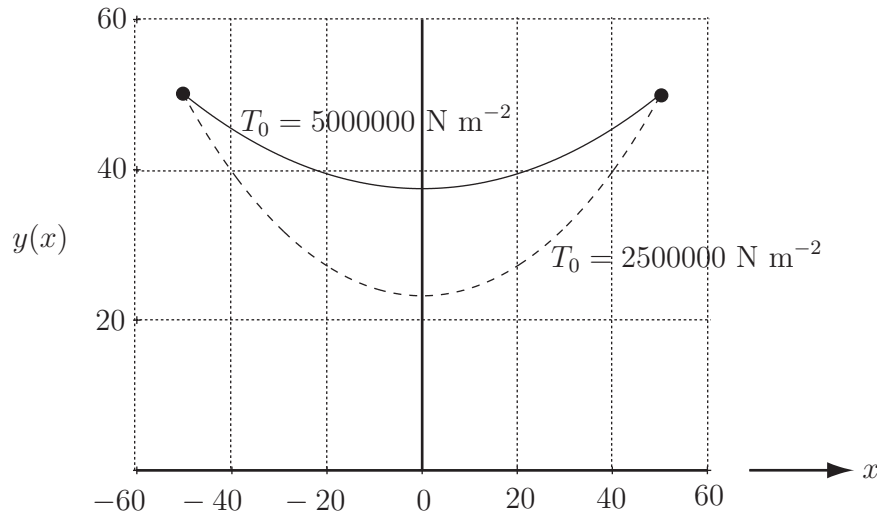

**Figure 9.2:** Graphs of the shapes of hanging cables with the same fixed end points (50 m high and 100 m apart) but different tensions

So

$$L = 2c \left( \sinh \left( \frac{d}{c} \right) \right). \quad (6)$$

Given the cable details and geometry used for Figure 9.2, the lengths are predicted to be just over 104 m for the cable with the higher tension and just under 109 m for the cable with the lower tension.

As remarked earlier, the maximum resultant tension  $T$  occurs at the ends of the cable where the vertical component of the tension is maximum. The vertical component of the tension is given by  $V = s\rho g$ . So its maximum value will occur where  $s = L/2$ , i.e. using (6),

$$V_{\max} = \rho g c \sinh \left( \frac{d}{c} \right) = T_0 \sinh \left( \frac{d}{c} \right)$$

Hence the magnitude of the maximum resultant tension is given by

$$\sqrt{T_0^2 + V_{\max}^2} = T_0 \sqrt{1 + \sinh^2 \left( \frac{d}{c} \right)} = T_0 \cosh \left( \frac{d}{c} \right)$$

Given the maximum tension at the cable ends, this can be used to calculate the horizontal tension and hence the value of  $c$ .



# Engineering Case Study 10

## Critical water height in an open channel

### Mathematical Skills

Topic	Workbook
Derivative of polynomials	[11]
Maxima and minima of functions	[12]
Integration	[13]

### Introduction

The modelling of open channel flows in natural streams, artificial canals, irrigation ditches as well as in partially filled pipes or tunnels is a common problem in fluid mechanics for hydraulic engineers. A typical problem might be to find the height of water flowing in the channel for a given flow rate.

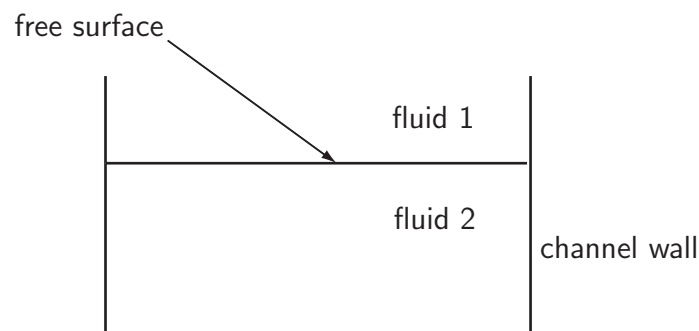

**Figure 10.1:** Vertical cross section through an open channel

Bernoulli's equation along a streamline, which is an expression of energy conservation, can be used to model fluid flow as long as the following assumptions are made:

- (i) The fluid flowing in the channel is incompressible and inviscid (no friction)
- (ii) The flow is steady (constant over time)
- (iii) The channel is straight, horizontal and of constant width
- (iv) The flow is uniform (all fluid droplets in a horizontal plane have the same speed)

For a given speed of the fluid  $u$ , the kinetic energy of flow per unit volume is  $\frac{1}{2}\rho u^2$  where  $\rho$  is the fluid density. At a given water height in the channel ( $z = h$ ) the potential energy per unit volume relative to the lowest point in the channel (height  $z = 0$ ) is  $\rho gh$  where  $g$  is the gravitational constant. The **specific energy** function  $E$  is given by the sum of the kinetic and potential energy per unit volume divided by  $\rho g$  i.e.

$$E = \frac{u^2}{2g} + h. \quad (1)$$

Note that the specific energy has the dimension of length.

Bernoulli's equation applied along a streamline in the free surface (see Figure 10.1) is given by

$$\frac{P_0}{\rho g} + \frac{u^2}{2g} + h = \text{constant} \quad (2)$$

where  $P_0$  is the atmospheric pressure and  $\rho$  is the fluid density. From (1) and (2)

$$\frac{P_0}{\rho g} + E = \text{constant} \quad (3)$$

As  $P_0$ ,  $\rho$  and  $g$  are constant,  $E$  is constant also. So, in an open horizontal channel, the specific energy is a constant of the flow. The critical fluid height and critical speed are defined to be when the specific energy of the fluid flow is a minimum.

### Problem in words

Water is flowing in a horizontal channel with cross section that is symmetrical about the central vertical axis. The channel cross section boundary height measured from the lowest point in the channel (the trough) is proportional to the fourth power of the horizontal distance from the axis of symmetry.

- (i) Express the critical water height in terms of the critical speed for a given constant volume flow rate and deduce the minimum specific energy for which flow is possible.
- (ii) Calculate the values of the critical fluid height and minimum specific energy if the flow rate is  $4 \text{ m}^3 \text{ s}^{-1}$  and the constant of proportionality characterising the channel cross sectional boundary is  $3 \text{ m}^{-3}$ .
- (iii) By plotting a graph of the dependence of the specific energy on the water height determine the possible flows and verify the critical fluid height and minimum specific energy results obtained above.

### Mathematical statement of problem

**I.** The channel profile is characterised by the curve  $z = ax^4$  in a reference frame where the origin  $O$  is at the trough, and  $a$  is a constant characterising the width of the channel profile (see Figure 10.2). For a given water height  $h$  in the channel, find an expression for the cross sectional area of fluid. Assuming that the fluid is inviscid and flowing at constant speed in any horizontal plane, deduce an expression for the volume flow rate  $V$  in terms of  $h$  and the speed of the fluid  $u$ .

**II.** Use Bernoulli's equation along a streamline to obtain the specific energy function and find its minimum for a given volume flow rate  $V$ . At the minimum of the specific energy function, the critical water height can be expressed in terms of the critical fluid speed.

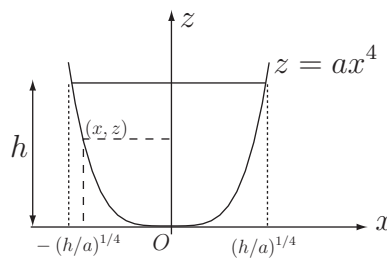

**Figure 10.2:** Channel profile and coordinate system

## Mathematical analysis

I. The area  $A$  of the cross section of fluid filling the channel up to height  $h$  can be defined by the difference between the cross section areas  $A_1$  and  $A_2$ , where  $A_1$  is the rectangular area between  $z = h$  and the  $x$ -axis for  $x$  in the range  $[-(h/a)^{1/4}, (h/a)^{1/4}]$  and  $A_2$  is the area between the curve  $z = ax^4$  and the  $x$ -axis for  $x$  in the range  $[-(h/a)^{1/4}, (h/a)^{1/4}]$ . Since the area  $A_1$  is rectangular,

$$A_1 = 2 \left( \frac{h}{a} \right)^{\frac{1}{4}} h \text{ or}$$

$$A_1 = 2 \frac{h^{5/4}}{a^{1/4}}. \quad (4)$$

Because of the symmetry of the curve  $ax^4$  with respect to the vertical axis, the area  $A_2$  is twice the area underneath the curve  $z = ax^4$  for  $x$  in the range  $[0, (h/a)^{1/4}]$ . So

$$A_2 = 2 \int_0^{(h/a)^{1/4}} ax^4 dx. \quad (5)$$

The integral (5) can be evaluated as  $A_2 = 2a \left[ \frac{x^5}{5} \right]_0^{(h/a)^{1/4}} = 2a \left[ \frac{1}{5} \left( \frac{h}{a} \right)^{5/4} - 0 \right]$  so that

$$A_2 = \frac{2h^{5/4}}{5a^{1/4}}. \quad (6)$$

From (4) and (6) the total area is given by

$$A = \frac{8h^{5/4}}{5a^{1/4}}. \quad (7)$$

The flow rate is given by the product of the cross sectional area and the fluid speed, i.e.  $V = A u$ . Hence using (7)

$$V = \frac{8h^{5/4}}{5a^{1/4}} u \quad (8)$$

The assumption of uniform flow ( $u$  is constant), means that  $V$  is constant also for a given fluid height in the channel.

II. Note from (1) that several pairs of values  $(u, h)$  may lead to the same constant value of  $E$ . If  $h$  is increased,  $u$  needs to be decreased to keep  $E$  constant. Considering now the dependence of  $E$  on variable  $h$ , find the critical value  $h_c$  that corresponds to a minimum in  $E(h)$ . Rearranging (8) to express  $u$  in terms of  $V$  and substituting for  $u$  in (1) results in

$$E = \frac{1}{2g} \left( \frac{5Va^{1/4}}{8h^{5/4}} \right)^2 + h$$

or

$$E = \frac{25V^2 a^{1/2} h^{-5/2}}{128g} + h \quad (9)$$

Taking the derivative of (9) with respect to  $h$  and keeping in mind that  $V$  is constant

$$\frac{dE}{dh} = -\frac{5}{2} \times \frac{25V^2 a^{1/2} h^{-7/2}}{128g} + 1$$

As the specific energy defined by (1) is a constant,  $\frac{dE}{dh} = 0$  at the critical fluid height  $h_c$ . So

$$\frac{125V^2 a^{1/2} h_c^{-7/2}}{256g} = 1$$

Solving for  $h_c$  gives

$$h_c = \left( \frac{125V^2 a^{1/2}}{256g} \right)^{2/7} \quad (10)$$

Substituting for  $V$  from (8) gives  $h_c = \left( \frac{125a^{1/2}}{256g} \right)^{2/7} \times \left( \frac{8h_c^{5/4}}{5a^{1/4}} u_c \right)^{4/7}$ .

After simplification, the relationship between critical fluid height  $h_c$  and the critical speed  $u_c$  corresponding to minimum specific energy becomes

$$h_c = \frac{5u_c^2}{4g} \quad (11)$$

Substituting the volume flow rate  $V$  from (8) in the specific energy Equation (9) gives the minimum specific energy for which fluid flow is possible in terms of the critical fluid level  $h_c$ , i.e.

$$E_{\min} = \frac{25 \left( \frac{8h_c^{5/4}}{5a^{1/4}} \right)^2 a^{1/2} h_c^{-5/2}}{128g} + h_c$$

Substituting for  $u_c$  from (11) gives

$$E_{\min} = \frac{25 \left( \frac{8h_c^{5/4}}{5a^{1/4}} \right)^2 \frac{4gh_c}{5} a^{1/2} h_c^{-5/2}}{128g} + h_c$$

which simplifies to

$$E_{\min} = \frac{7h_c}{5} \quad (12)$$

(ii) If the flow rate  $V = 4 \text{ m}^3 \text{ s}^{-1}$  and the constant,  $a$ , defining the channel profile is  $3 \text{ m}^{-3}$ , then using  $g = 9.8 \text{ m s}^{-2}$  and (10)  $h_c = \left( \frac{125 \times 4^2 3^{1/2}}{256 \times 9.8} \right)^{2/7}$ , or

$$h_c \approx 1.01 \text{ m}. \quad (13)$$

The minimum energy may be evaluated using (12) and

$$E_{\min} \approx 1.53 \text{ m}. \quad (14)$$

(iii) Equation (9) may be used to plot the specific energy function  $E(h)$  and the graph is shown in Figure 10.3. Note that the minimum of the curve occurs for values  $h_c$  and  $E_{\min}$  that are consistent with results (13) and (14).



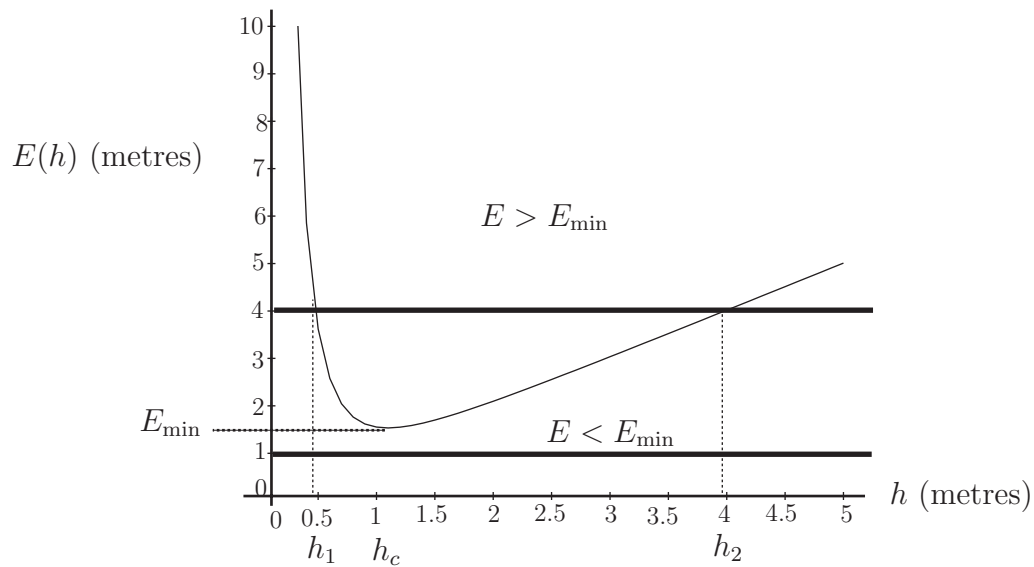

**Figure 10.3:** Dependence of the specific energy on the fluid height in open channel flow

### Interpretation

The graph (Figure 10.3) shows that

1. When  $E > E_{\min}$ , two flows may occur at different fluid height  $h_1$  and  $h_2$  that correspond to fluid speed  $u_1$  and  $u_2$  respectively. The flow characterised by the values  $h_1$  and  $u_1$  is often named “shallow and fast” (or **supercritical**), while the flow characterised by the values  $h_2$  and  $u_2$  is named “deep and slow” (or **subcritical**) as  $h_2 > h_1$  and  $u_2 < u_1$ .
2. When  $E = E_{\min}$ , only one flow may occur for critical fluid height  $h_c$  and critical speed  $u_c$ .
3. When  $E < E_{\min}$ , no flow is possible.



# Engineering Case Study 11

## Simple pendulum

### Mathematical Skills

Topic	Workbook
Algebra - rearranging formulae	[1]

### Introduction

A simple pendulum is made by fixing a short metal bar horizontally at the end of a string of length  $L$ . Some students drop a ball bearing from a variable height  $H$  directly above the bar at the instant when it passes through the centre of its swing and try to hit the bar at its next return to that position. Show that they should start their attempt at a height  $H$  which is slightly less than  $5L$ . (Hint: neglect air resistance; you need to know the standard formula for the periodic time of a pendulum).

### Mathematical analysis

The standard formula for the time for the bar to perform a half oscillation (centre to end and back) is given by

$$T = \pi \sqrt{\frac{L}{g}}$$

For a particle dropping from rest the relationship between the time of fall  $t$  and the distance  $X$  fallen is  $X = \frac{1}{2}gt^2$ . We wish to choose  $X$  so that the time of fall equals the half-period of the pendulum's swing. This leads to the result:

$$\pi \sqrt{\frac{L}{g}} = \sqrt{\frac{2X}{g}}$$

Squaring the terms on both sides leads to the result that  $X = \frac{\pi^2}{2}L$ .

Since  $\pi^2$  is nearly 10 (actually about 9.8696) it follows that the height  $X$  is nearly  $5L$ . Note that the value of  $g$  does not enter into the result, since it cancels from both sides of the equation. The attempts to hit the swinging bar should start from about  $H = 5L$  but will need to be carried out by trial and error, since there are two features which mean that our calculation is only approximate. First, the effect of air resistance will make the time of fall of the ball bearing a little longer than the time given by our calculation. Secondly, the textbook equation for the periodic time of a pendulum is only accurate for oscillations of small amplitude and when air resistance is negligible. To keep the pendulum swinging for several oscillations it will presumably be given a fairly large initial amplitude of swing; for large amplitudes of swing the periodic time is a little longer than that given by the traditional equation.

## Motion of a pendulum

### Mathematical Skills

Topic	Workbook
Trigonometric functions	[4]
Derivative of a product and function of a function	[11]
Maclaurin expansion	[16]
Contour plotting for a function of two variables	[18]
Linear second order ODEs	[19]

### Introduction

A simple pendulum consists of a “point mass” of mass  $m$  swinging in a vertical plane at the end of a thin rod of length  $l$  and negligible weight. The angle  $\theta(t)$  is measured anti-clockwise from the vertical and denotes the displacement angle which the rod makes with the vertical (see Figure 12.1). Frictional effects of all kinds are neglected.

The potential energy of a swinging mass,  $m$ , is defined by  $E_p = mgh$  where  $h$  is the height of the mass above its rest position (see Figure 12.1). When the system is isolated from any external force, the total energy  $E = E_k + E_p$  of the system is conserved (i.e. it is constant) and can be written as a function of the two variables  $\theta(t)$  and  $\frac{d\theta(t)}{dt}$ . In the remainder of this study the time dependence will not be shown explicitly and the notation  $\dot{\theta}$  and  $\ddot{\theta}$  will be used for  $\frac{d\theta}{dt}$  and  $\frac{d^2\theta}{dt^2}$ .

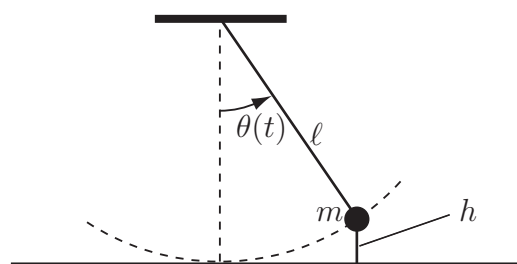

**Figure 12.1:** Parameters defining the motion of the pendulum

### Problem in words

Formulate a model for the motion of the pendulum mass. Use this to determine the motion when

- the mass is released from rest when the pendulum is horizontal
- when the mass is given an initial instantaneous angular velocity of  $30 \text{ rad s}^{-1}$  when in its lowest position
- when the angle of displacement of the pendulum is small.

## Mathematical statement of problem

1. Use an energy method. Given that  $E_k = \frac{1}{2}mv^2$  represents the kinetic energy of a mass  $m$  in motion at instantaneous speed  $v(t)$  (varying with time  $t$ ) derive an expression for the rotational kinetic energy expressed in terms of the angular speed  $\dot{\theta}$  (derivative of the instantaneous angle with respect to time).
2. Express the potential energy in terms of  $m$ ,  $g$ ,  $l$ , and  $\cos\theta(t)$  where  $g$  is the gravitational constant.
3. Hence show that the total energy  $E$ , which is a function of  $\theta$  and  $\dot{\theta}$ , at any instant, is given by

$$E = \frac{1}{2} ml^2 \dot{\theta}^2 + mgl(1 - \cos\theta(t)). \quad (1)$$

4. Assuming that  $g = 9.8 \text{ m s}^{-2}$ ,  $l = 0.07 \text{ m}$  and using the variable ranges  $-10 \text{ rad} < \theta(t) < 10 \text{ rad}$  and  $-30 \text{ rad s}^{-1} < \frac{d\theta(t)}{dt} < 30 \text{ rad s}^{-1}$ , plot contours of the function

$$\frac{1}{ml^2} E = \frac{1}{2} \dot{\theta}^2 + \frac{g}{l}(1 - \cos\theta(t)) \quad (2)$$

in terms of the variables  $\theta(t)$ ,  $\dot{\theta}(t)$ .

5. Since  $m$ ,  $l$  and  $E$  are constant during the motion, Equation (2) implies that the initial conditions  $\theta(t=0)$  and  $\dot{\theta}(t=0)$  determine the constant of the motion,  $\frac{E}{ml^2}$ . Each contour line represents a constant energy value  $E$  for variation in the coordinates  $\theta(t)$  and  $\frac{d\theta(t)}{dt}$ . The value of  $\frac{E}{ml^2}$  defines each contour of the plot and characterizes the motion of the pendulum. Use the contour plot to describe the pendulum motion in the following cases:

Case A:  $\theta(0) = \pi/2$  and  $\left. \frac{d\theta}{dt} \right|_{t=0} = 0$ .

Case B: when the mass is in the lowest vertical position and has an angular speed  $30 \text{ rad s}^{-1}$  at  $t = 0$ .

Case C:  $\theta$  is small such that  $\sin\theta \approx \theta$ .

6. Since it is assumed that the system is isolated from any external force, the total energy is conserved, i.e.  $E$  is constant in time and  $dE/dt = 0$ . Taking the time derivative of Equation (1), show that the differential equation of the motion is:

$$\ddot{\theta} + \lambda^2 \sin\theta = 0 \quad (3)$$

where  $\lambda^2 = g/l$ .

7. (a) Retaining only the first term of the Maclaurin expansion of the sine function for small arguments, approximate Equation (3) as a linear second order differential equation.  
(b) Find a solution of this differential equation.  
(c) Hence deduce that the motion is periodic and find an expression for the period in terms of the pendulum length.

## Mathematical analysis

1. The kinetic energy of a mass  $m$  moving at a speed  $v$  is given by  $E_k = \frac{1}{2}mv^2$ . The mass moves along an arc whose radius is  $l$  through a distance  $ds(t) = v(t)dt$  during an infinitesimal time interval  $dt$ . Consequently, the speed of the mass can be expressed at time  $t$  by  $v(t) = \frac{ds(t)}{dt}$ . On the other hand, if the angle of rotation  $\theta(t)$  is expressed in radians,  $s(t) = l\theta(t)$  so that  $v(t) = \frac{ds(t)}{dt} = \frac{d[l\theta(t)]}{dt}$ . The rod length is fixed during the motion, so  $l$  does not depend on time  $t$ , consequently  $v(t) = \frac{d[l\theta(t)]}{dt} = l \frac{d[\theta(t)]}{dt} = l\dot{\theta}$ . Replacing  $v(t)$  by this expression, the kinetic energy  $E_k$  can be expressed as  $E_k = \frac{1}{2}ml^2\dot{\theta}^2$ .
2. The goal is to obtain  $E_p$  in terms of the parameters  $m$ ,  $g$ ,  $l$ , and the variable  $\cos\theta(t)$ . Consequently, the height  $h$  of the mass above its position at rest, needs to be expressed in terms of these quantities. Since  $h$  is the difference between the length  $l$  of the pendulum (also the radius of the circular trajectory) and the distance  $l\cos\theta$  between the axis of rotation and the orthogonal projection of the point mass  $m$  on the vertical,  $h = l - l\cos\theta = l(1 - \cos\theta)$ . Replacing  $h$  by this expression, the potential energy is given by  $E_p = mgl(1 - \cos\theta)$ .
3. The total energy is the sum of the kinetic and potential energy  $E = E_k + E_p$  therefore  $E = \frac{1}{2}ml^2\dot{\theta}^2 + mgl(1 - \cos\theta)$ .
4. Figure 12.2 shows the contour plot of  $\frac{E}{ml^2}$  as a function of the two variables  $\theta$  and  $\dot{\theta}$  (HELM 18).

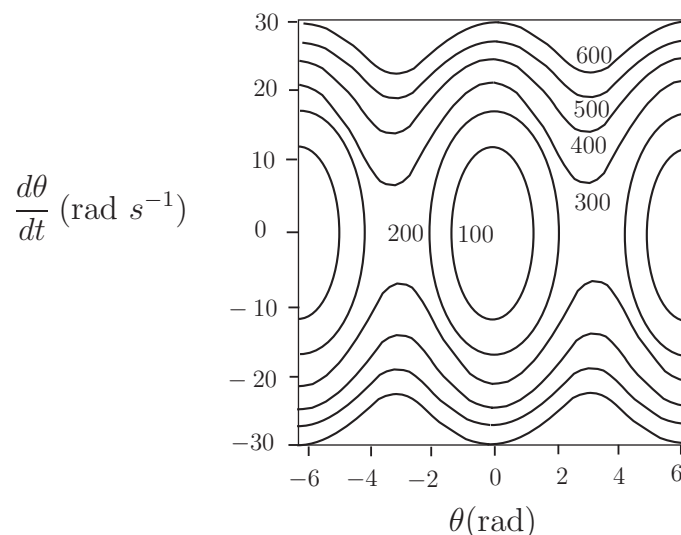

**Figure 12.2:** Contour plots of the ratio for the simple pendulum

5. We consider each case:

Case A:  $\theta(0) = \pi/2$  and  $\dot{\theta}(t=0) = 0$

Equation (2) implies that  $\frac{E}{ml^2} = \frac{1}{2}\dot{\theta}^2(t=0) + \frac{g}{l}(1 - \cos \theta(0))$  is a constant when the pendulum is isolated from external forces. Using  $\theta(t=0) = \pi/2$  and  $\dot{\theta}(t=0) = 0$  gives  $\frac{E}{ml^2} = g/l \approx 140(\text{rad s}^{-1})^2$ . This contour of constant energy  $E$  is located in Figure 12.2 between the two closed contour labeled  $\frac{E}{ml^2} = 100 (\text{rad s}^{-1})^2$  and  $200 (\text{rad s}^{-1})^2$ .

Case B: If the mass is in the lowest vertical position and has an angular speed  $30 \text{ rad s}^{-1}$  at  $t = 0$ , then  $\theta(t=0) = 0$  and  $\dot{\theta}(t=0) = 30 \text{ rad s}^{-1}$ . The corresponding contour for constant energy is given by  $\frac{E}{ml^2} = (30)^2/2 \approx 450 (\text{rad s}^{-1})^2$ .

Case C: The case when  $\theta$  is small is considered in 6 and 7 below.

6. Taking the time derivative of Equation (1) using the fact that  $E$ ,  $m$ ,  $l$ ,  $g$  are constant in time, gives  $0 = \frac{1}{2}ml^2 \frac{d}{dt}[\dot{\theta}]^2 - mgl \frac{d}{dt}[\cos \theta]$ . Using the expression for a derivative of a product (for the first term) and the derivative of a function of function (for the second term) this relation becomes:

$$0 = ml^2 \dot{\theta}[\ddot{\theta}] + mgl \dot{\theta} \sin \theta.$$

After dividing by  $ml^2 \dot{\theta}$  and using the definition  $\lambda^2 = g/l$ , this becomes

$$\ddot{\theta} + \lambda^2 \sin \theta = 0,$$

as required.

7. (a) The Maclaurin expansion (HELM 16.5) for the sine function is:

$$\sin \theta = \theta - \theta^3/3! + \dots$$

For small angles, the sum can be truncated after the first term i.e.  $\sin \theta \approx \theta$ .

Differential Equation (3) becomes:

$$\ddot{\theta} + \lambda^2 \theta = 0.$$

(b) This equation is a linear second order differential equation with constant coefficients for which it is necessary to find a complementary function  $\theta(t)$  (HELM 19.3). The standard procedure to solve such equations is to seek the roots of the auxiliary equation

$$(m^2 + \lambda^2)e^{mt} = 0.$$

This is satisfied if  $m^2 + \lambda^2 = 0$  or  $m^2 = -\lambda^2$ . Consequently the roots  $m$  are complex i.e.  $m = \pm i\lambda$ .

The solutions of the differential equation can be expressed as  $\theta(t) = Ae^{i\lambda t} + Be^{-i\lambda t}$ . Other ways of writing these solutions are

$$\theta = C \sin \lambda t + D \cos \lambda t \quad \text{or} \quad \theta = F \cos(\lambda t - \phi)$$

where  $A, B, C, D, F$  and  $\phi$  are constants that are determined from the initial conditions.

- (c) The equations of the motion obtained in (b) are periodic according to the trigonometric functions  $\sin \lambda t$ ,  $\cos \lambda t$  or  $\cos(\lambda t - \phi)$ . The period of the trigonometric functions of argument  $\lambda t$  is  $2\pi$  therefore  $\lambda t = 2\pi$  implies a period  $T = 2\pi/\lambda$  for the pendulum motion oscillating with small angles such that  $\sin \theta \approx \theta$ . Using  $\lambda^2 = g/l$ , the period of the oscillations can be expressed in terms of the length of the pendulum as  $T = 2\pi\sqrt{\frac{l}{g}}$ .

### Interpretation

The predictions in Figure 12.2 show that two types of motion of the pendulum are possible depending on the value of the ratio  $\frac{E}{ml^2}$ . These types of motion are illustrated by the two specific examples.

For Case A, a closed contour is the result (an ellipse as in Figure 12.2). The range of position angles and the angular speeds are restricted. For the contour  $\frac{E}{ml^2} = 200 \text{ (rad s}^{-1}\text{)}^2$  the restrictions are, approximately, that  $-2 \text{ rad} < \theta < 2 \text{ rad}$  and  $-20 \text{ rad s}^{-1} < d\theta/dt < 20 \text{ rad s}^{-1}$ . Consequently, the angular variation in the pendulum motion is restricted and the motion is oscillatory. The lowest point of a closed contour corresponds to the pendulum rod in a vertical position ( $\theta = 0$ ). Negative rotational speeds indicate clockwise oscillation since positive angles indicate anti-clockwise rotation. The rotational speed magnitude is maximum at the lowest point i.e. the kinetic energy is maximum and the potential energy is minimum. The right-most point on a closed contour indicates a maximum pendulum angle magnitude and minimum angular speed magnitude i.e. minimum kinetic energy ( $0 \text{ rad s}^{-1}$ ) and maximum potential energy.

For Case B with initial conditions such that  $\frac{E}{ml^2} = (30)^2/2 \approx 450 \text{ (rad s}^{-1}\text{)}^2$ , the corresponding contour is not closed and there is no restriction on the angles allowed during the motion. The motion is a rotation in which the angle varies monotonically with time. The angular speed oscillates between a low and high bound that correspond to the maximum potential energy (kinetic energy minimum at the top of the circular motion) and the minimum potential energy (kinetic energy is maximum at the bottom of the circular motion).

For Case C simple harmonic motion results and we have the simple pendulum of Engineering Case Study 11.

## The falling snowflake

### Mathematical Skills

Topic	Workbook
Integration	[13]
First order ODEs	[19]
Second order linear ODEs	[19]
Vector differentiation	[28]

### Introduction

Although the resisted motion of objects with fixed mass was considered in HELM 34.3 in the Workbook on Modelling Motion, and related to projectile contexts, there are applications where the mass of the moving object varies with time. The particular case considered here is the falling snowflake. This is an example from nature but there are engineering contexts such as in food processing where similar analysis may be relevant.

### Problem in words

A snowflake falling vertically is subjected to a frictional force proportional to its mass and speed. Moreover, the condensation of water vapour is increasing the mass of the snowflake at a rate proportional to its mass. Find the time dependence of the snowflake's vertical position assuming that it starts from rest with a mass  $m_0$ . Also find the time dependence of the snowflake's mass.

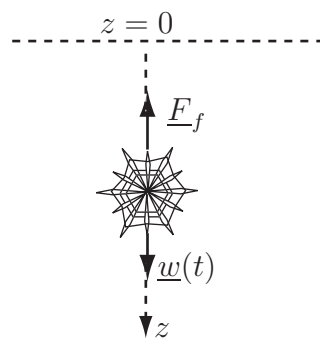

**Figure 13.1:** Forces on the falling snowflake and parameters involved in the mathematical formulation

### Mathematical statement of problem

The snowflake shown in Figure 13.1 is undergoing a vertical frictional force  $\underline{F}_f$  proportional to the mass,  $m(t)$ , and to the speed of the flake,  $v(t)$ , therefore

$$|\underline{F}_f| = cm(t)v(t) \quad (1)$$

where  $c$  is a constant (coefficient of air friction). The snowflake is subject to a downward vertical force i.e. its weight



$$|\underline{w}(t)| = m(t)g \quad (2)$$

where  $g$  is the acceleration due to gravity. The condensation of water vapour is increasing the mass  $m(t)$  of the snowflake at a rate proportional to the mass of the flake such that

$$\frac{dm(t)}{dt} = km(t) \quad (3)$$

where  $k$  is a constant. The vertical position  $z(t)$  of the flake with respect to time  $t$  is subjected to the initial conditions

- (i) speed  $v(t = 0) = 0$
- (ii) mass  $m(t = 0) = m_0$
- (iii)  $z(t = 0) = 0$ .

**I** Write the ordinary differential equation (ODE) of the second order in  $z(t)$  obtained by applying the general form of Newton's law

$$\sum_n \underline{F}_n = \frac{d(m(t)\underline{v}(t))}{dt} \quad (4)$$

which states the equality between the sum of all external forces on the snowflake and the rate of change of the snowflake's momentum.

**II** Solve by the two methods of solving the resulting ODE:

- (a) The second order ODE in  $z(t)$  can be solved using the results from the general theory.
- (b) The same result can be derived by solving the first order ODE  $v(t) = \frac{dz(t)}{dt}$  by direct integration.

**III** Find the time dependence of the snowflake mass  $m(t)$  by direct integration of Equation (3).

## Mathematical analysis

### I ODE of the motion using Newton's law

The weight  $\underline{w}(t)$  and the frictional force  $\underline{F}_f$  (see HELM 34.3) are the only two external forces considered in this study. With the choice of vertical axis  $z$  shown in Figure 13.1, use of Equations (2) and (1) in Newton's law (Equation (4)) leads to

$$m(t)g - cm(t)v(t) = \frac{d(m(t)v(t))}{dt}. \quad (5)$$

(The time-dependence of  $m$  and  $v$  is considered implicit from now on so we write  $m$  for  $m(t)$  and  $v$  for  $v(t)$ .)

This is based on the hypothesis that the coordinate system is a reference frame in which (4) is valid. The goal is to obtain a ODE in terms of the function  $z(t)$  only, therefore, the rule about the derivative of a product of functions is used as both the mass and the speed depend on time,

$$\frac{d(mv)}{dt} = m\frac{dv}{dt} + v\frac{dm}{dt}.$$

Equation (3) implies

$$\frac{d(mv)}{dt} = m\frac{dv}{dt} + vkm.$$

Using this expression in (5), and cancelling  $m$

$$\frac{dv}{dt} + [k + c]v = g. \quad (6)$$

Recalling that  $v = \frac{dz}{dt}$ , Equation (6) becomes

$$\frac{d^2z}{dt^2} + [k + c]\frac{dz}{dt} = g. \quad (7)$$

### II(a) Solution using the general theory for second order ODE

This equation is a linear second order differential equation with constant coefficients for which it is necessary to find a complementary function  $z(t)$  (HELM 19.3). The standard procedure to solve such equations is to seek the roots of the auxiliary equation

$$m^2 + [k + c]m = 0.$$

This is satisfied if  $m = -[k + c]$  or  $m = 0$ . Consequently, the roots  $m$  are real and the complementary function of the differential equation can be expressed as

$$z(t) = Ae^{-[k+c]t} + B, \quad \text{where } A \text{ and } B \text{ constants}$$

It is easy to check that a particular solution of Equation (7) is  $z(t) = \frac{g}{k+c}t + D$  and, by summation of the two solutions (complementary function + particular solution) the general solution is

$$z(t) = Ae^{-[k+c]t} + \frac{g}{k+c}t + E \quad (8)$$

where  $E$  is a constant ( $= B + D$ ).

The initial condition (iii)  $z(t = 0) = 0$  implies that  $Ae^{-[k+c] \times 0} + E = 0$  so  $E = -A$ . Consequently, (8) becomes

$$z(t) = A\{e^{-[k+c]t} - 1\} + \frac{g}{k+c}t. \quad (9)$$

The initial condition (i)  $v(0) = 0$  implies that  $\left. \frac{dz}{dt} \right|_{t=0} = 0$ .

The derivative of (9) is

$$\frac{dz}{dt} = -A[k + c]e^{-[k+c]t} + \frac{g}{k+c}.$$

Therefore,  $\left. \frac{dz}{dt} \right|_{t=0} = 0$  implies  $-A[k + c]e^{-[k+c] \times 0} + \frac{g}{k+c} = 0$  which gives  $A = \frac{g}{(k+c)^2}$ . Equation (9) becomes

$$z(t) = \frac{g}{(k+c)^2} \{e^{-[k+c]t} - 1 + [k+c]t\}. \quad (10)$$

### II(b) Solution using an integration of the first order ODE in $v(t)$

Starting from the ODE (6) one can write  $dv = [g - [k + c]v]dt$ , and integrating both sides of the equality using the initial condition (i)  $v(0) = 0$

$$\int_0^v \frac{dv}{g - [k + c]v} = \int_0^t dt. \quad (11)$$

Changing variables, the expression  $\frac{dv}{g - [k + c]v}$  can be written as  $-\frac{1}{k+c} \frac{dY}{Y}$  where  $Y = g - [k + c]v$ .

Note that at  $t = 0$ ,  $Y = g$ .

Therefore (11) becomes

$$-\frac{1}{k+c} \int_g^Y \frac{dY}{Y} = \int_0^t dt. \quad (12)$$

Recall from HELM 11.2 that the derivative of  $\ln |Y|$  is given as  $1/|Y|$ , so (12) becomes,

$$t = -\frac{1}{k+c} (\ln |Y| - \ln g) = -\frac{1}{k+c} \ln \left( \frac{|Y|}{g} \right)$$

Replacing the variable  $Y$  in terms of  $v(t)$ ,

$$t = -\frac{1}{k+c} \ln \left\{ \frac{|g - [k+c]v|}{g} \right\}.$$

Taking the exponential of both sides and solving for  $v$  one finds that

$$v = \frac{g}{k+c} \{1 - e^{-t[k+c]}\}. \quad (13)$$

Recall the definition  $v = \frac{dz}{dt}$  and the initial condition (iii)  $z(0) = 0$ , then integrate (13):

$$\int_0^z dz = \frac{g}{k+c} \int_0^t \{1 - e^{-[k+c]t}\} dt$$

which leads to

$$z(t) = \frac{g}{(k+c)^2} \{e^{-[k+c]t} - 1 + [k+c]t\}.$$

### III. Time dependence of the snowflake mass

The snowflake mass  $m(t)$  can be obtained by direct integration of Equation (3), i.e.

$$\frac{dm}{dt} = km.$$

Hence

$$\int_{m_0}^m \frac{dm}{m} = k \int_0^t dt.$$

Use of the initial condition (ii)  $m(0) = m_0$  gives

$$kt = \left[ \ln m \right]_{m_0}^m$$

so

$$m = m_0 e^{kt}.$$

### Interpretation

The snowflake's speed reaches a terminal value  $v = \frac{g}{k+c}$  as can be seen by putting  $\frac{dv}{dt} = 0$  in Equation (6). The snowflake's mass increases exponentially but when the weight becomes counter-balanced by the frictional force, the total force on the system is zero and the snowflake falls at the constant speed  $v = \frac{g}{k+c}$ .

## Satellite motion

### Mathematical Skills

Topic	Workbook
Trigonometry	[4]
Equation of conics in polar coordinates	[17]
Second order ODEs	[19]
Vector calculus	[28]
Polar coordinate system	[28]

### Problem in words

Apply Newton's law in a polar coordinate system to deduce the differential equation as well as a constant of the motion of a satellite idealised as a point mass in the gravitational field of a planet with centre of mass fixed at the origin. Solve the differential equation for the trajectory of the satellite and prove Kepler's first law that the orbit can be written in the form of the equation of a conic.

### Mathematical statement of problem

The gravitational force on a satellite of mass  $m$  (with centre of mass at  $P$ ) circling the Earth of mass  $M$  (with centre of mass at  $O$ ) due to the gravitational field is given by

$$\underline{F} = -G \frac{mM}{r^2} \hat{r}, \quad (1)$$

where  $G$  is the gravitational constant,  $r$  is the distance between the two centre of mass,  $\hat{r}$  is the unit vector along the radial axis in the direction of increasing  $r$ . Newton's law  $\underline{F} = m\underline{a}$  together with the general result of the acceleration  $\underline{a}$  in polar coordinates for the motion of a material point in a plane (result derived in HELM 47.3 Physics Case Study 11)

$$\underline{a} = \left[ \frac{d^2r}{dt^2} - r \left( \frac{d\theta}{dt} \right)^2 \right] \hat{r} + \left[ 2 \frac{dr}{dt} \frac{d\theta}{dt} + r \frac{d^2\theta}{dt^2} \right] \hat{\theta}, \quad (2)$$

allow to write the equations of the motion of the satellite. Kepler's first law is obtained by establishing a relationship between variables  $r$  and  $\theta$  by elimination of the time variable out of the equations of the motion. The second order differential equation obtained is solved by changing variable  $r$  to  $1/r$ .

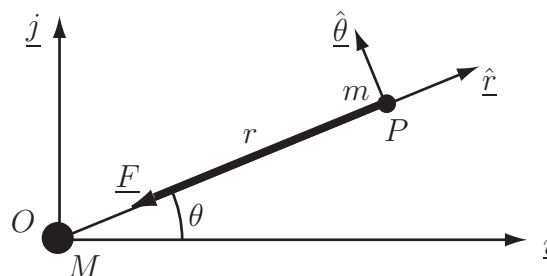

**Figure 14.1:** Gravitational force and coordinate systems

### Mathematical analysis

Applying Newton's law with Equations (1) and (2) leads to

$$-G \frac{mM}{r^2} \hat{r} = m \left[ \frac{d^2 r}{dt^2} - r \left( \frac{d\theta}{dt} \right)^2 \right] \hat{r} + m \left[ 2 \frac{dr}{dt} \frac{d\theta}{dt} + r \frac{d^2 \theta}{dt^2} \right] \hat{\theta}, \quad (3)$$

The basis vectors  $(\hat{r}, \hat{\theta})$  have been chosen to be independent (non-collinear), therefore (3) leads to the two equations,

$$-G \frac{M}{r^2} = \frac{d^2 r}{dt^2} - r \left( \frac{d\theta}{dt} \right)^2 \quad (4)$$

$$2 \frac{dr}{dt} \frac{d\theta}{dt} + r \frac{d^2 \theta}{dt^2} = 0. \quad (5)$$

noting that  $\frac{d}{dt} \left( r^2 \frac{d\theta}{dt} \right) = 2r \frac{dr}{dt} \frac{d\theta}{dt} + r^2 \frac{d^2 \theta}{dt^2}$ , Equation (5) multiplied by  $r$  leads to

$$\frac{d}{dt} \left( r^2 \frac{d\theta}{dt} \right) = 0, \quad (6)$$

therefore,

$$r^2 \frac{d\theta}{dt} \equiv C \quad (7)$$

is a constant of the motion. Note that  $C$  is often defined as the ratio of the angular momentum  $L$  and the mass  $m$  of the satellite as  $C = r^2 \frac{d\theta}{dt} = \frac{L}{m}$ .

Using (7), Equation (4) can be written

$$-G \frac{M}{r^2} = \frac{d^2 r}{dt^2} - \frac{C^2}{r^3}. \quad (8)$$

We now wish to derive the equation of the orbit in the form of a relation between  $r$  and  $\theta$ . Defining the variable  $u \equiv 1/r$ , (8) becomes

$$-G M u^2 = \frac{d^2 r}{dt^2} - C^2 u^3. \quad (9)$$

Taking the time derivative of  $r$  and replacing  $r$  by  $1/u$  gives

$$\frac{dr}{dt} = \frac{d}{dt} \left( \frac{1}{u} \right) = -\frac{1}{u^2} \frac{du}{dt}. \quad (10)$$

One is seeking to eliminate the time variable out of (9), therefore, applying the chain rule on the time derivative of  $u$  gives

$$\frac{dr}{dt} = -\frac{1}{u^2} \frac{du}{d\theta} \frac{d\theta}{dt}. \quad (11)$$

Equation (7) allows us to write  $\frac{d\theta}{dt} = C u^2$  and (11) becomes

$$\frac{dr}{dt} = -C \frac{du}{d\theta}. \quad (12)$$

Taking the time derivative of (12) with the chain rule leads to

$$\frac{d^2r}{dt^2} = -C \frac{d}{dt} \left( \frac{du}{d\theta} \right) = -C \frac{d}{d\theta} \left( \frac{du}{d\theta} \right) \frac{d\theta}{dt}. \quad (13)$$

Substituting for  $\frac{d\theta}{dt}$  from Equation (7) in (13) leads to

$$\frac{d^2r}{dt^2} = -C^2 u^2 \frac{d^2u}{d\theta^2}. \quad (14)$$

The differential equation of the motion is deduced from (9) as

$$-G M u^2 = -C^2 u^2 \frac{d^2u}{d\theta^2} - C^2 u^3. \quad (15)$$

Equation (15) can be divided by  $-C^2 u^2$ , and the definition  $K \equiv GM$  allows us to obtain the final differential equation in variable  $u$ :

$$\frac{d^2u}{d\theta^2} + u = \frac{K}{C^2}. \quad (16)$$

The solution of the second order differential equation (16) is given by the sum of the complementary function and the particular integral  $\frac{K}{C^2}$ . The complementary function is obtained from solving the auxiliary equation  $k^2 + 1 = 0$  which leads to  $k = \pm i$ . Therefore, the solution of (16) can be written as  $u(\theta) = A \cos \theta + B \sin \theta + \frac{K}{C^2}$  or in the form  $u(\theta) = D \cos(\theta - \theta_0) + \frac{K}{C^2}$ . Taking out a factor  $\frac{K}{C^2}$  and making the variable  $r$  the subject leads to  $\frac{1}{r} = \frac{K}{C^2} \left[ 1 + \frac{C^2}{K} D \cos(\theta - \theta_0) \right]$  and the orbit of the satellite in terms of the polar angle  $\theta$  is expressed as the equation of a conic in polar coordinates

$$r = \frac{\frac{C^2}{K}}{1 + \frac{C^2 D}{K} \cos(\theta - \theta_0)}. \quad (17)$$

### Interpretation

The parameter  $e \equiv \frac{C^2 D}{K}$  is the eccentricity, the point  $O$  is one of the foci of the conic and the line  $\theta = \theta_0$  is the focal axis. Engineering Case Study 15 which follows next shows that all values of eccentricity  $e$  are possible and that the trajectory can be an ellipse ( $e < 1$ ), an hyperbola ( $e > 1$ ), exceptionally a parabola ( $e = 1$ ), or a circle of centre  $O$  and radius  $\frac{C^2}{K}$ , depending on the initial velocity of the satellite launch.



# Engineering Case Study 15

## Satellite orbits

### Mathematical Skills

Topic	Workbook
Trigonometry	[4]
Equation of conics in polar coordinates	[17]
Second order ODEs	[19]
Vector calculus	[28]
Polar coordinate system	[28]

### Introduction

The use of satellites as telecommunication devices, global positioning tools or for scientific data gathering to monitor the Earth's atmosphere, oceans and surface is increasing. Engineers in charge of planning the data acquisition and information transmission to the Earth's surface need to compute the orbit of the satellite according to the laws of gravitation stated by Newton. This case study shows that the initial velocity at launch is crucial in determining the satellite orbit.

### Problem in words

- I. Use Newton's law in polar coordinates to deduce the differential equation and a constant for the motion of a satellite idealised as a point object in the gravitational field of the Earth with centre of mass fixed at the origin.
- II. Solve the differential equation for the trajectory of the satellite and prove Kepler's first law that the trajectory can be written in the form of the equation of a conic.
- III. Show that the trajectory of the satellite can be elliptic, hyperbolic or parabolic depending on the magnitude of the launch velocity.

### Mathematical statement of problem

- I. The gravitational force due to the Earth of mass  $m'$  at  $O$  on a satellite idealised as a point object of mass  $m$  with centre of mass at  $P$  is

$$\underline{F} = -G \frac{mm'}{r^2} \hat{r}, \quad (1)$$

where  $G$  is the gravitational constant,  $r$  is the distance between the two centre of mass,  $\hat{r}$  is the unit vector along the radial axis in the direction of increasing  $r$  (see Figure 15.1). To use Newton's law  $\underline{F} = m\underline{a}$  to obtain the equations of the motion of the satellite, the first step is to find an expression for the acceleration  $\underline{a}$  in polar coordinates for the motion of a point in a plane. The second order differential equation of motion is obtained by

- (a) establishing a relationship between variables  $r$  and  $\theta$
- (b) eliminating the time variable from the equations of the motion
- (c) changing variable  $r$  to  $u \equiv 1/r$ .

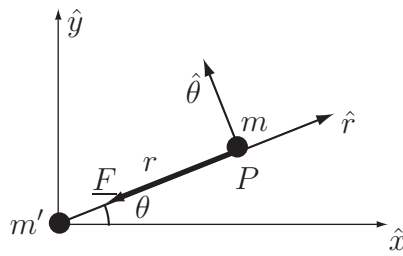

**Figure 15.1:** Gravitational force and coordinate systems

**II.** The solution of the second order differential equation of the motion is given by the sum of the complementary function and the particular integral. Kepler's first law is obtained by establishing a relationship between variables  $r$  and  $\theta$  in the form of the equation of a conic.

**III.** Expressing the initial velocity  $V_0$  of the satellite in a polar coordinate system (see Figure 15.2), find the integration constants of the solution  $u \equiv 1/r$  of the differential equation of the motion in terms of the radial position of the satellite  $r_0$  at  $t = 0$ , the velocity magnitude  $V_0$  (at  $t = 0$ ), the launch angle  $\alpha_0$ ,  $K \equiv Gm'$ , and a constant of the motion defined as

$$C \equiv r^2 \frac{d\theta}{dt}. \quad (2)$$

Discuss the possible trajectories of the satellite in terms of the values of the eccentricity of the conic equation obtained, and show that the trajectory types depend solely on the initial velocity magnitude.

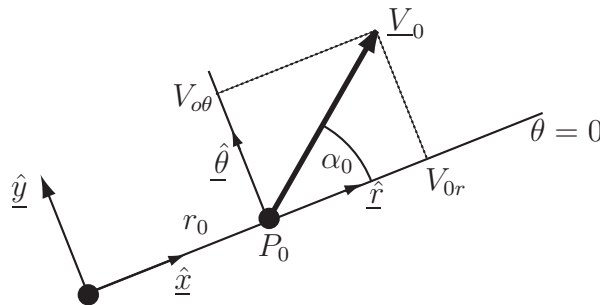

**Figure 15.2:** Initial velocity in a polar coordinate system at  $t = 0$

### Mathematical analysis

**I.** The equations of the motion of the satellite are given by Newton's law  $\underline{F} = m\underline{a}$ . Consider the general planar motion of a point  $P$  whose position is given in polar coordinates. Express the radial and angular components of the acceleration  $\underline{a}$  in polar coordinates. The point  $P$  represents, in this example, the centre of mass of a satellite idealised as a point object in the gravitational field of the Earth. The position of a point  $P$  can be defined by the Cartesian coordinates  $(x, y)$  of the position vector  $\underline{OP} = x\underline{i} + y\underline{j}$  as shown in Figure 15.3 where  $\underline{i}$  and  $\underline{j}$  are the unit vectors along the coordinate axes. The Cartesian coordinates  $(x, y)$  can be expressed in terms of the polar coordinates  $(r, \theta)$ , i.e.

$$x = r \cos \theta \quad (3)$$

and

$$y = r \sin \theta. \quad (4)$$



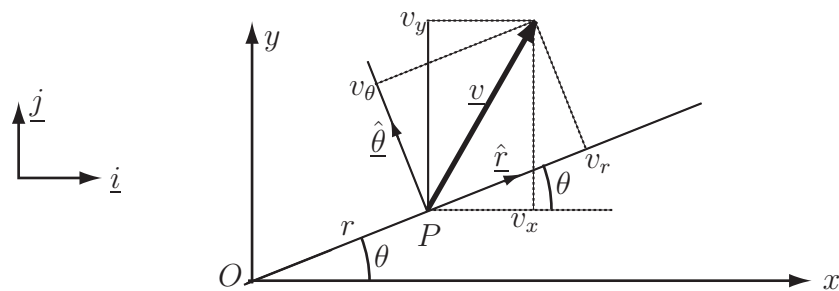

**Figure 15.3:** Cartesian and polar coordinate system

The velocity of  $P$  is  $\underline{v} = \frac{d}{dt}(\underline{OP})$ . So, since  $\underline{OP} = x\underline{i} + y\underline{j}$ , the components  $(v_x, v_y)$  of velocity  $\underline{v} = v_x\underline{i} + v_y\underline{j}$  in the frame  $(\underline{i}, \underline{j})$  are derived from the time derivatives of (3) and (4) noting the fact that  $\frac{d\underline{i}}{dt} = \underline{0}$  and  $\frac{d\underline{j}}{dt} = \underline{0}$  since the unit vectors along  $Ox$  and  $Oy$  are fixed with time. Hence

$$v_x = \frac{dx}{dt} = \frac{dr}{dt} \cos \theta - r \frac{d\theta}{dt} \sin \theta \quad (5)$$

$$v_y = \frac{dy}{dt} = \frac{dr}{dt} \sin \theta + r \frac{d\theta}{dt} \cos \theta. \quad (6)$$

The components  $(a_x, a_y)$  of acceleration  $\underline{a} = a_x\underline{i} + a_y\underline{j}$  in the frame  $(\underline{i}, \underline{j})$  are obtained from the time derivative of  $\underline{v}$  i.e. from the time derivatives of (5) and (6). Hence

$$a_x = \frac{d^2x}{dt^2} = \frac{d^2r}{dt^2} \cos \theta - 2 \frac{dr}{dt} \frac{d\theta}{dt} \sin \theta - r \left( \frac{d\theta}{dt} \right)^2 \cos \theta - r \frac{d^2\theta}{dt^2} \sin \theta \quad (7)$$

$$a_y = \frac{d^2y}{dt^2} = \frac{d^2r}{dt^2} \sin \theta + 2 \frac{dr}{dt} \frac{d\theta}{dt} \cos \theta - r \left( \frac{d\theta}{dt} \right)^2 \sin \theta + r \frac{d^2\theta}{dt^2} \cos \theta. \quad (8)$$

The components  $(v_x, v_y)$  of velocity and  $(a_x, a_y)$  of acceleration are expressed in terms of the polar coordinates. Since the velocity vector  $\underline{v}$  is the same in both basis sets,

$$v_x\underline{i} + v_y\underline{j} = v_r\underline{\hat{r}} + v_\theta\underline{\hat{\theta}}. \quad (9)$$

Projections of the basis vector  $(\underline{i}, \underline{j})$  onto the basis vectors  $(\underline{\hat{r}}, \underline{\hat{\theta}})$  leads to (see Figure 15.4)

$$\underline{i} = \cos \theta \underline{\hat{r}} - \sin \theta \underline{\hat{\theta}} \quad (10)$$

$$\underline{j} = \sin \theta \underline{\hat{r}} + \cos \theta \underline{\hat{\theta}} \quad (11)$$

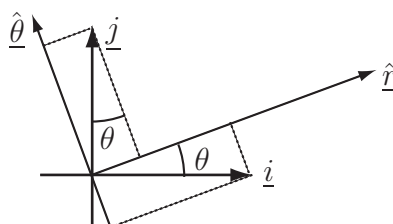

**Figure 15.4:** Projections of the Cartesian basis set onto the polar basis set

Equation (9) together with (10) and (11) gives

$$v_x(\cos \theta \hat{r} - \sin \theta \hat{\theta}) + v_y(\sin \theta \hat{r} + \cos \theta \hat{\theta}) = v_r \hat{r} + v_\theta \hat{\theta}. \quad (12)$$

The basis vectors  $(\hat{r}, \hat{\theta})$  have been chosen to be independent, therefore (12) leads to the two equations:

$$v_r = v_x \cos \theta + v_y \sin \theta \quad (13)$$

$$v_\theta = -v_x \sin \theta + v_y \cos \theta. \quad (14)$$

Using (5) and (6) in (13) and (14) gives

$$v_r = \frac{dr}{dt} \quad (15)$$

$$v_\theta = r \frac{d\theta}{dt}. \quad (16)$$

The same method can be used for the components  $(a_r, a_\theta)$  of the acceleration. The equation  $\underline{a} = a_x \underline{i} + a_y \underline{j} = a_r \hat{r} + a_\theta \hat{\theta}$  gives

$$a_r = a_x \cos \theta + a_y \sin \theta \quad (17)$$

$$a_\theta = -a_x \sin \theta + a_y \cos \theta. \quad (18)$$

Using (5) and (6) in (15) and (16) leads to the radial and angular components of the acceleration  $\underline{a}$  in polar coordinates

$$a_r = \frac{d^2 r}{dt^2} - r \left( \frac{d\theta}{dt} \right)^2 \quad (19)$$

$$a_\theta = 2 \frac{dr}{dt} \frac{d\theta}{dt} + r \frac{d^2 \theta}{dt^2}. \quad (20)$$

The angular velocity  $\frac{d\theta}{dt}$  and acceleration  $\frac{d^2 \theta}{dt^2}$  are often denoted by  $\omega$  and  $\alpha$  respectively. The component of velocity along  $\hat{\theta}$  is  $r\omega$ . The component of acceleration along  $\hat{r}$  includes not only the so-called radial acceleration  $\frac{d^2 r}{dt^2}$  but also  $-r\omega^2$  which is the **centripetal acceleration** or the acceleration toward the origin. The  $-r\omega^2$  term is the only radial term that applies in cases of circular motion since, for  $r$  constant,  $\frac{d^2 r}{dt^2} = 0$ . The acceleration along  $\hat{\theta}$  includes not only the term  $r\alpha$ , but also the **Coriolis acceleration**  $2 \frac{dr}{dt} \omega$ .

Substituting the radial and angular components of the acceleration in polar coordinates (19) and (20) into the Newton's law, Equation (1) leads to

$$-G \frac{mm'}{r^2} \hat{r} = m \left[ \frac{d^2 r}{dt^2} - r \left( \frac{d\theta}{dt} \right)^2 \right] \hat{r} + m \left[ 2 \frac{dr}{dt} \frac{d\theta}{dt} + r \frac{d^2 \theta}{dt^2} \right] \hat{\theta}. \quad (21)$$

Using again the fact that the basis vectors  $(\hat{r}, \hat{\theta})$  have been chosen to be independent means that the  $\hat{r}$  and  $\hat{\theta}$  components can be equated, leading to

$$-G \frac{m'}{r^2} = \frac{d^2 r}{dt^2} - r \left( \frac{d\theta}{dt} \right)^2 \quad (22)$$

and

$$2 \frac{dr}{dt} \frac{d\theta}{dt} + r \frac{d^2\theta}{dt^2} = 0. \quad (23)$$

Noting that  $\frac{d}{dt} \left( r^2 \frac{d\theta}{dt} \right) = 2r \frac{dr}{dt} \frac{d\theta}{dt} + r^2 \frac{d^2\theta}{dt^2}$ , Equation (23) multiplied by  $r$  leads to

$$\frac{d}{dt} \left( r^2 \frac{d\theta}{dt} \right) = 0. \quad (24)$$

therefore,

$$r^2 \frac{d\theta}{dt} \equiv C \quad (25)$$

is a constant of the motion. Note that  $C$  is often defined as the ratio of the angular momentum  $L$  and the mass  $m$  of the satellite as  $C = r^2 \frac{d\theta}{dt} = \frac{L}{m}$ .

Using (25), Equation (22) can be written

$$-G \frac{m'}{r^2} = \frac{d^2r}{dt^2} - \frac{C^2}{r^3}. \quad (26)$$

We now wish to derive the equation of the trajectory under the form of a relation between  $r$  and  $\theta$ . Defining the variable  $u \equiv \frac{1}{r}$ , (26) becomes

$$-G m' u^2 = \frac{d^2r}{dt^2} - C^2 u^3. \quad (27)$$

Taking the time derivative of  $r$  and replacing  $r$  by  $1/u$  gives

$$\frac{dr}{dt} = \frac{d}{dt} \left( \frac{1}{u} \right) = -\frac{1}{u^2} \frac{du}{dt}. \quad (28)$$

To eliminate the time variable from (28), apply the chain rule on the time derivative of  $u$  to give

$$\frac{dr}{dt} = -\frac{1}{u^2} \frac{du}{d\theta} \frac{d\theta}{dt}. \quad (29)$$

From (25) and using  $u \equiv \frac{1}{r}$ , we have  $\frac{d\theta}{dt} = C u^2$ , and so (29) becomes

$$\frac{dr}{dt} = -C \frac{du}{d\theta}. \quad (30)$$

Taking the time derivative of (30) by means of the chain rule leads to

$$\frac{d^2r}{dt^2} = -C \frac{d}{dt} \left( \frac{du}{d\theta} \right) = -C \frac{d}{d\theta} \left( \frac{du}{d\theta} \right) \frac{d\theta}{dt}. \quad (31)$$

Using (25) in (31) leads to

$$\frac{d^2r}{dt^2} = -C^2 u^2 \frac{d^2u}{d\theta^2}. \quad (32)$$

The differential equation of motion is deduced from (27) as

$$-G m' u^2 = -C^2 u^2 \frac{d^2u}{d\theta^2} - C^2 u^3. \quad (33)$$

Dividing (33) by  $-C^2u^2$  and using the definition  $K \equiv Gm'$  gives the final form of the differential equation in terms of variable  $u$

$$\frac{d^2u}{d\theta^2} + u = \frac{K}{C^2}. \quad (34)$$

The solution of this second order differential equation is the sum of the complementary function and the particular integral  $\frac{K}{C^2}$ . The complementary function is obtained by solving the auxiliary equation  $k^2 + 1 = 0$  which gives  $k = \pm i$ . Therefore, the solution of (34) can be written as  $u(\theta) = A \cos \theta + B \sin \theta + \frac{K}{C^2}$  or in the alternative form  $u(\theta) = D \cos(\theta - \theta_0) + \frac{K}{C^2}$ . Taking out a factor  $\frac{K}{C^2}$  and reverting to variable  $r$  leads to

$$\frac{1}{r} = \frac{K}{C^2} \left[ 1 + \frac{C^2}{K} D \cos(\theta - \theta_0) \right].$$

Finally, the trajectory of the satellite in terms of the polar angle  $\theta$  can be expressed as the equation of a conic in polar coordinates

$$r = \frac{\frac{C^2}{K}}{1 + \frac{C^2 D}{K} \cos(\theta - \theta_0)}. \quad (35)$$

The parameter  $e \equiv \frac{C^2 D}{K}$  is the eccentricity, the point  $O$  is one of the foci of the conic and the line  $\theta = \theta_0$  is the focal axis. Solution to Question III, given below, shows that all values of eccentricity  $e$  are possible and that the trajectory can be an ellipse ( $e < 1$ ), an hyperbola ( $e > 1$ ), exceptionally a parabola ( $e = 1$ ), or a circle of centre  $O$  and radius  $\frac{C^2}{K}$ , depending on the initial velocity of the satellite launch.

**III.** The solution of the differential Equation (34) is chosen in the form

$$u(\theta) = A \cos \theta + B \sin \theta + \frac{K}{C^2} \quad (36)$$

The constants  $A, B$  and  $C$  are determined from the initial conditions of the launch. at  $t = 0$ . The initial radial position of the satellite, at point  $P_0(r_0, \theta_0)$  or  $P_0(u_0, \theta_0)$ , can be defined as

$$r = r_0 \text{ at } t = 0. \quad (37)$$

The radial axis can be chosen to coincide with the  $x$ -axis at  $t = 0$  (see Figure 2), and therefore

$$\theta = \theta_0 \text{ at } t = 0. \quad (38)$$

Note that the initial condition (37) can be expressed also as  $u = u_0 = 1/r_0$  at  $t = 0$ . At  $t = 0$ , the satellite has velocity  $\underline{V}_0$  given by (see Figure 2),

$$\underline{V}_0 = V_{0r} \hat{r} + V_{0\theta} \hat{\theta}. \quad (39)$$

Equations (15) and (16) give the components of the velocity  $\underline{v}$  in terms of polar coordinates as

$$\underline{v} = \frac{dr}{dt} \hat{r} + r \frac{d\theta}{dt} \hat{\theta}. \quad (40)$$

Equation (40) can be expressed in terms of the variable  $u$ . Using the chain rule, the first right-hand

side term in (40) can be written  $\frac{dr}{dt} = \frac{dr}{d\theta} \frac{d\theta}{dt}$ . Using (25), i.e.  $\frac{d\theta}{dt} = \frac{C}{r^2}$ ,  $\frac{dr}{dt} = \frac{C}{r^2} \frac{dr}{d\theta}$  and the definition  $u \equiv 1/r$  leads to  $\frac{dr}{dt} = Cu^2 \frac{d(u^{-1})}{d\theta} = -C \frac{du}{d\theta}$ . Defining  $u' \equiv \frac{du}{d\theta}$ , the first right-hand side term in (40) becomes

$$\frac{dr}{dt} = -Cu' \quad (41)$$

The second right-hand side term in (40) is  $r \frac{d\theta}{dt}$  that can be expressed as  $r \frac{d\theta}{dt} = r \frac{C}{r^2}$ . After simplification

$$r \frac{d\theta}{dt} = uC. \quad (42)$$

Using (41) and (42), Equation (40) becomes

$$\underline{v} = -Cu' \hat{r} + Cu \hat{\theta}. \quad (43)$$

It can be deduced from Figure 2 that  $V_{0r} = V_0 \cos \alpha_0$  and  $V_{0\theta} = V_0 \sin \alpha_0$ . Therefore, (43) leads to

$$V_0 \cos \alpha_0 = -Cu'_0 \quad (44)$$

and

$$V_0 \sin \alpha_0 = Cu_0. \quad (45)$$

Using  $u_0 = 1/r_0$  in (45) gives the constant,

$$C = r_0 V_0 \sin \alpha_0, \quad (46)$$

and in (44) gives  $u'_0 = -\frac{V_0 \cos \alpha_0}{C}$  which, after using (46), can be written as

$$u'_0 = -\frac{\cos \alpha_0}{r_0 \sin \alpha_0}. \quad (47)$$

Using the initial conditions (37) and (38) in (36) gives

$$u(0) = A \cos(0) + B \sin(0) + \frac{K}{C^2} \text{ or}$$

$$u_0 = A + \frac{K}{C^2}. \quad (48)$$

Taking the first derivative of (36) with respect to variable  $\theta$  leads to an additional equation for the constant  $B$ . Indeed,  $\left. \frac{du}{d\theta} \right|_{\theta=0} = -A \sin(0) + B \cos(0)$ , so

$$B = u'_0. \quad (49)$$

From (48), the constant  $A$  can be expressed as  $A = u_0 - \frac{K}{C^2}$ .

Substituting for  $C$  from (46) leads to  $A = \frac{1}{r_0} - \frac{K}{r_0^2 V_0^2 \sin^2 \alpha_0}$ .

After defining  $\eta_0 \equiv \frac{r_0 V_0^2}{K}$ ,

$$A = \frac{1}{r_0} \left( 1 - \frac{1}{\eta_0 \sin^2 \alpha_0} \right). \quad (50)$$

From (49) and (47), the constant  $B$  can be expressed as

$$B \equiv -\frac{\cos \alpha_0}{r_0 \sin \alpha_0}. \quad (51)$$

With the use of  $\frac{K}{C^2} = \frac{K}{r_0^2 V_0^2 \sin^2 \alpha_0} = \frac{1}{r_0 \eta_0 \sin^2 \alpha_0}$  and (50) and (51), Equation (36) can be expressed as a function of the parameters  $r_0$ ,  $V_0$ ,  $\alpha_0$ ,  $K$  and  $\theta$ . Hence,

$$u(\theta) = \frac{1}{r_0} \left( 1 - \frac{1}{\eta_0 \sin^2 \alpha_0} \right) \cos \theta - \frac{\cos \alpha_0}{r_0 \sin \alpha_0} \sin \theta + \frac{1}{r_0 \eta_0 \sin^2 \alpha_0},$$

or, after taking the factor  $\frac{1}{r_0 \eta_0 \sin^2 \alpha_0}$  out of  $u(\theta)$ ,

$$u(\theta) = \frac{1}{r_0 \eta_0 \sin^2 \alpha_0} \{ 1 + (\alpha_0 \sin^2 \alpha_0 - 1) \cos \theta - \eta_0 \sin \alpha_0 \cos \alpha_0 \sin \theta \}. \quad (52)$$

The radial position of the satellite is obtained by rearranging (52) as

$$r(\theta) = \frac{r_0 \eta_0 \sin^2 \alpha_0}{1 + (\eta_0 \sin^2 \alpha_0 - 1) \cos \theta - \eta_0 \sin \alpha_0 \cos \alpha_0 \sin \theta}. \quad (53)$$

The denominator in (53) is of the form  $E \cos \theta + F \sin \theta$  with  $E = \eta_0 \sin^2 \alpha_0 - 1$  and  $F = -\eta_0 \sin \alpha_0 \cos \alpha_0$ . To recover the usual form

$$r(\theta) = \frac{p}{1 + e \cos(\theta - \varphi)} \quad (54)$$

of the equation of a conic with eccentricity  $e$  and parameter  $p = r_0 \eta_0 \sin^2 \alpha_0$  in polar coordinates, the trigonometric identity  $e \cos(\theta - \phi) = e \cos \theta \cos \phi + e \sin \theta \sin \phi$  is used (see HELM 4.3 Key Point 17, page 46).

Comparing this to  $E \cos \theta + F \sin \theta$  and equating factors of  $\cos \theta$  and  $\sin \theta$ , gives  $e \cos \phi = E$  and  $e \sin \phi = F$ .

Squaring these and summing, gives  $e^2 \cos^2 \phi + e^2 \sin^2 \phi = E^2 + F^2$  or  $e^2 = E^2 + F^2$ . Therefore,

$$e^2 = (\eta_0 \sin^2 \alpha_0 - 1)^2 + \eta_0^2 \sin^2 \alpha_0 \cos^2 \alpha_0.$$

After expanding the first term and using  $\cos^2 \alpha_0 = 1 - \sin^2 \alpha_0$  in the second term the equation for eccentricity becomes

$$e^2 = 1 + \eta_0^2 \sin^4 \alpha_0 - 2\eta_0 \sin^2 \alpha_0 + \eta_0^2 \sin^2 \alpha_0 (1 - \sin^2 \alpha_0).$$

The terms in  $\sin^4 \alpha_0$  cancel to leave

$$e^2 - 1 = \eta_0(\eta_0 - 2) \sin^2 \alpha_0. \quad (55)$$

The sign of  $e^2 - 1$  which depends on the values of  $\eta_0$ , determines the trajectory type of the satellite. In (55), the launch angle  $\alpha_0$  occurs only in the square of the sine function and this is always positive. Consequently the launch angle  $\eta_0$  has no effect on either the sign of  $e^2 - 1$  or, therefore, on the trajectory type.

Recalling general results from HELM 17.1 and 17.3 on conic sections:

1. if  $\eta_0 < 2$ ,  $e^2 - 1 < 0$  and  $e^2 < 1$ . Therefore  $e < 1$  and the trajectory is an elliptical orbit. Note that  $e = 0$  is obtained for  $E = F = 0$  (or  $A = B = 0$ ), and Equation (21) becomes  $r(\theta) = p$ . The trajectory of the satellite occurs at constant radial distance  $p = r_0 \eta_0 \sin^2 \alpha_0$  from the centre of the polar coordinate system (the centre of the Earth), therefore, the orbit is circular.
2. if  $\eta_0 = 2$ ,  $e^2 - 1 = 0$  which implies  $e^2 = 1$ . Therefore,  $e = 1$  and the trajectory is parabolic.
3. if  $\eta_0 > 2$ ,  $e^2 - 1 > 0$  leading to  $e^2 > 1$ . Consequently,  $e > 1$  and the trajectory is hyperbolic.

### Interpretation

Since  $\eta_0 \equiv \frac{r_0 V_0^2}{K}$ , the threshold value  $\eta_0 = 2$  that determines the trajectory types implies a velocity magnitude  $V_0 = \sqrt{\frac{2K}{r_0}}$ . Therefore the trajectory types depend solely on the launch velocity magnitude and

1. if  $V_0 < \sqrt{\frac{2K}{r_0}}$ ,  $e < 1$ , the orbit is elliptical,
2. if  $V_0 = \sqrt{\frac{2K}{r_0}}$ ,  $e = 1$ , the trajectory is parabolic,
3. if  $V_0 > \sqrt{\frac{2K}{r_0}}$ ,  $e > 1$ , the trajectory is hyperbolic.

Note that for an initial radial position  $r_0$  of the satellite (measured from the origin of the polar coordinate system at the center of the Earth), the threshold magnitude of launch velocity, i.e. the “escape speed”, that permits the satellite to leave the gravitational field of the Earth is  $V_0^{\text{esc}} = \sqrt{\frac{2K}{r_0}}$ . As long as the launch velocity is less than the escape speed, the satellite follows an **elliptical orbit** around the Earth after launch.



# Engineering Case Study 16

## Underground railway signals location

### Mathematical Skills

Topic	Workbook
Trigonometry	[4]
Differentiation of inverse trig functions	[11]
Geometry (arc length)	[17]
Partial differentiation	[18]

### Introduction

The location of signals in a curved underground railway tunnel is important since the train driver needs to be able to see them in time to stop at them safely. Alternatively, an advance indication of the approaching signals has to be given. At a speed of  $35 \text{ km hr}^{-1}$  the minimum distance along the track required to give the driver time to react to seeing the signals in time for the train to stop and have a safety margin, is 42 m. Usually, the train driver's eyes are in the centre of the tunnel. Typically, the signal is located 0.25 m from the side of the tunnel, at the driver's eye height, on the outside of the curve.

### Problem in words

An underground railway is to be extended to a new Olympic sports stadium. The tunnel has a diameter of 4 m and the centre line of the tunnel is curved in the form of an arc of a circle with a radius of 200 m. Assume that the maximum speed of the train is  $35 \text{ km hr}^{-1}$ , that the train driver's eyes are in the centre of the tunnel, both vertically and horizontally, and that the signal is 0.25 m from the side of the tunnel, at the driver's eye height, on the outside of the curve. The uncertainty in the tunnel radius at any point is 0.25 m. Moreover the actual position of the signal may, in practice, be up to 0.02 m from its intended position, while the movement of the train and the variation in the driver's characteristics means that the driver's viewpoint may vary by 0.5 m from the position quoted.

- Calculate the point at which the driver first sees the signal, and the uncertainty in that calculation caused by the variations in the signal position and driver's position. Is there sufficient visibility for the train to stop safely without advance indication?
- A new design of train will move the driver's position 0.6 m to the left. Can this design of train be introduced without requiring extra signals?



## Mathematical statement of problem

- Figure 16.1 depicts the situation

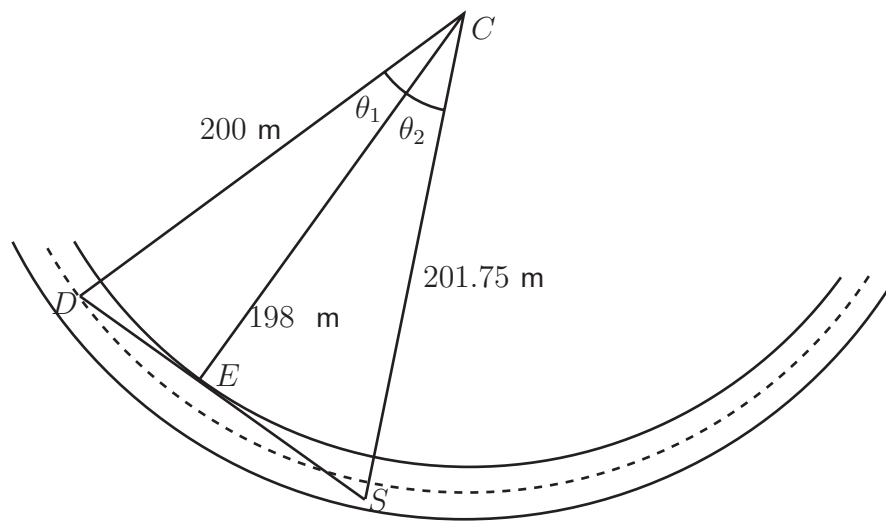

**Figure 16.1**

- Calculate the angle  $\theta_1$  subtended at the virtual centre of the radius of curvature of the rail ( $C$ ) by the length from the driver ( $D$ ) to the edge of the tunnel ( $E$ ) where the line of sight from the driver to the signals touches the tunnel.
- Calculate the angle  $\theta_2$  subtended at the virtual centre of the radius of curvature of the rail ( $C$ ) by the length from the signals ( $S$ ) to the edge of the tunnel ( $E$ ) where the line of sight from the driver to the signals touches the tunnel.
- Calculate the expected distance along the rails between the positions of the signals and the driver.
- Use partial differentiation to deduce the variation in these distances resulting from variations on signals and driver positions. For example if  $x$  denotes the radius of the tunnel and  $y$  denotes the distance from the edge of the tunnel along the line of sight to the driver, use

$$\Delta\theta_1 = \frac{\partial\theta_1}{\partial x}\Delta x + \frac{\partial\theta_1}{\partial y}\Delta y$$

- Hence calculate the possible range of distances along the track and compare the resulting range to the required minimum distance.

## Mathematical analysis

The geometry of the situation to be modelled is shown in Figure 16.1 above where  $C$  denotes the virtual centre of the tunnel curvature.

- (a) The line of sight  $DS$  from the driver to the signal grazes the tunnel at  $E$ , so  $CE$  is perpendicular to  $DS$ . The radius of the centre line of the tunnel is 200 m, so  $CE = 198$  m,  $CD = 200$  m and  $CS = 201.75$  m. Therefore the angle  $\theta_1 = \cos^{-1}\left(\frac{198}{200}\right) = 0.1415$  radians (to 4 d.p.)

and  $\theta_2 = \cos^{-1} \left( \frac{198}{201.75} \right) = 0.1931$  radians (to 4 d.p.). Therefore the distance between driver and signal along the rails (calculated as the distance along the centre line) is

$$200(\theta_1 + \theta_2) = 66.92 \text{ m}$$

We round this down to 66 m for the worst case scenario (as lower is less safe).

We need to calculate the uncertainty in this distance. Let  $x$  denote the radius of the tunnel and  $y$  the distance from the edge of the tunnel to the driver along  $CD$ , i.e. 2 m. This means that  $CD = x + y$ , so that  $\theta_1 = \cos^{-1} \left( \frac{x}{x + y} \right)$ .

$$\text{Hence } \frac{\partial \theta_1}{\partial x} = -\frac{1}{\sqrt{1 - \left( \frac{x}{x + y} \right)^2}} \times \frac{y}{(x + y)^2} = -\frac{y}{(x + y)\sqrt{2xy + y^2}} \quad (1)$$

$$\text{Hence } \frac{\partial \theta_1}{\partial y} = -\frac{1}{\sqrt{1 - \left( \frac{x}{x + y} \right)^2}} \times \frac{-x}{(x + y)^2} = \frac{x}{(x + y)\sqrt{2xy + y^2}} \quad (2)$$

Changes of  $\Delta x$  in  $x$  and  $\Delta y$  in  $y$  produce a change  $\Delta \theta_1 = \frac{\partial \theta_1}{\partial x} \Delta x + \frac{\partial \theta_1}{\partial y} \Delta y$  in  $\theta_1$ .

Since  $x = 198$  and  $y = 2$  then

$$\Delta \theta_1 = \frac{\partial \theta_1}{\partial x} \Delta x + \frac{\partial \theta_1}{\partial y} \Delta y = -0.0003544 \Delta x + 0.03509 \Delta y \quad (\text{to 4 sig.fig.}).$$

The uncertainty in the radius of the tunnel ( $\Delta x$ ) is 0.25 m and that in the position of the driver ( $\Delta y$ ) is 0.5 m. These could have either sign. So the maximum error is when  $\Delta x = +0.25$  and  $\Delta y = -0.5$ , giving  $\Delta \theta_1 = 0.01764$ . As we have worked to 4 significant figures (and these are only approximations) the last figure is uncertain.

For the uncertainty in  $\theta_2$  (related to the track length between  $E$  and  $S$ ),  $x = 198$  and  $\Delta x = 0.25$  as before. Moreover the expressions (1) and (2) can be used for the partial derivatives of  $\theta_2$  except that now  $y = 3.75$  and  $\Delta y = 0.02$ . So

$$\Delta \theta_2 = \frac{\partial \theta_2}{\partial x} \Delta x + \frac{\partial \theta_2}{\partial y} \Delta y = -0.0004801 \Delta x + 0.02535 \Delta y = 0.000627$$

The total uncertainty in the distance along the track centre-line between  $D$  and  $S$  is

$$200(\Delta \theta_1 + \Delta \theta_2) = 3.6754 \text{ m.}$$

- (b) For the revised position of the driver we have  $y = 1.4$  and  $x = 198$ . This gives  $\theta_1 = \cos^{-1} \left( \frac{198}{199.4} \right) = 0.1267$  radians, and  $\Delta \theta_1 = 0.0212$ .  $\theta_2$  and  $\Delta \theta_2$  are as before so the distance along the track is  $200(0.3198) = 63.96$  m and the uncertainty is  $200(0.02216) = 4.432$  m.

## Interpretation

- (a) As we have worked to four figures only the result 3.6769 m is uncertain, so round upwards to 3.8 m or 4 m to the nearest metre (i.e. increase the uncertainty). So the actual distance is between  $66 - 4 = 62$  m and  $66 + 4 = 70$  m. Both are greater than the minimum acceptable distance of 42 m, so no additional signal is required.
- (b) Rounding up the result of 4.432 m again, the range is (in whole metres) between 59 m and 69 m. Again this is greater than the minimum acceptable distance, so no additional signal is required.



# Engineering Case Study 17

## Heat conduction through a wine cellar roof

### Mathematical Skills

Topic	Workbook
Trigonometry	[4]
First order ODEs	[19]
Second order ODEs	[19]
Fourier series	[23]
Partial differential equations	[25]

### Introduction

When the surface of the ground is heated by the sun the temperature on the surface varies on a diurnal cycle. If it is assumed that the temperature is uniform over an area of the surface and varies with time and depth and the temperature at depth  $z$  and time  $t$  is denoted by  $\theta(z, t)$ , it is known that  $\theta(z, t)$  satisfies the diffusion equation:

$$\frac{\partial \theta}{\partial t} = k \frac{\partial^2 \theta}{\partial z^2} \quad (1)$$

where  $k$  is a positive constant i.e. the conductivity of the ground,  $\theta$  is measured in degrees Celsius,  $z$  is measured in metres (measured with the positive direction downwards),  $t$  is time in hours, and the value of  $k$  for soil may be taken to be  $1.8 \times 10^{-3} \text{ m}^2 \text{ hr}^{-1}$ . A simple function that represents the variation of temperature with time at the surface is

$$\theta(0, t) = \theta_0 + A(0) \cos \omega t \quad (2)$$

for some constants  $\theta_0$ ,  $A(0)$  and  $\omega$ .

### Problem in words

A discerning engineer wishes to build a wine cellar consisting of a hole in the ground lined with concrete sides and with a concrete roof which is covered in soil to an appropriate depth. Access to the wine cellar is to be along a tunnel from an existing cellar. The requirement is that the temperature in the wine cellar should not change appreciably over short periods. More precisely, the daily variation should be no more than  $0.5^\circ\text{C}$ . If it is assumed that convection provides reasonable transmission of heat within the cellar, then it is required that the temperature of the soil varies by no more than  $0.5^\circ\text{C}$  immediately above the cellar's roof. Given that the maximum daily variation at the surface of the ground is  $40^\circ\text{C}$ , how deep should the roof of the wine cellar be to ensure that the daily variation is no more than  $0.5^\circ\text{C}$ ?

**Mathematical statement of problem**

- (i) Given that the period of the diurnal variation of the temperature at the surface described in Equation (2) is 24 hours ( $t$  is measured in hours), that the maximum temperature is at  $t = 0$  (noon) and the maximum variation is  $40^\circ\text{C}$ , calculate  $\omega$  and  $A(0)$ .
- (ii) For the temperature at depth  $z$  in the soil, assume a solution of the form

$$\theta(z, t) = \theta_0 + A(z) \cos(\omega t - Cz) \quad (3)$$

where  $C$  is a positive constant and  $A(z)$  depends on  $z$  only. Substitute the expression (3) into (1) and equate coefficients of sine and cosine terms to find expressions for  $C$  and hence  $\theta(z, t)$ .

- (iii) Use the resulting amplitude in the expression for  $\theta(z, t)$  to deduce the value of  $z$  such that the amplitude is less than 0.5.

**Mathematical analysis**

- (i)  $\omega = 2\pi/24 = \pi/12$ .

If  $\theta(0, t) = \theta_0 + A(0) \cos \omega t$ , the maximum and minimum values are  $\theta_0 + A(0)$  and  $\theta_0 - A(0)$ . So for the maximum variation (which is  $2A(0)$ ) to be  $40^\circ\text{C}$ , requires  $A(0) = 20$ .

- (ii) For  $\theta(z, t) = \theta_0 + A(z) \cos(\omega t - Cz)$  to satisfy the differential equation (1), we must have that

$$-A(z)\omega \sin(\omega t - Cz) = k\{A''(z) \cos(\omega t - Cz) + 2A'(z)C \sin(\omega t - Cz) - A(z)C^2 \cos(\omega t - Cz)\}.$$

As the equation holds for all  $t$  and  $z \geq 0$ , we can equate the coefficients of the cosine and sine terms (or equivalently for any fixed  $z$ , we can choose  $t$  so that the sine term is 0 to equate the coefficients of the cosine, and choose  $t$  so that the cosine term is 0 to equate the coefficients of the sine). This gives a first order ODE and a second order ODE:

$$-A(z)\omega = 2kCA'(z) \quad (4)$$

$$0 = A''(z) - A(z)C^2 \quad (5)$$

Equation (4) when solved gives  $A(z) = A \exp(-\frac{\omega}{2kC}z)$  for some constant  $A$  and Equation (5) gives

$$C^2 = \left(\frac{\omega}{2kC}\right)^2, \quad \text{or} \quad C^2 = \frac{\omega}{2k}, \quad \text{or} \quad C = \sqrt{\frac{\omega}{2k}} \quad (\text{since } C \text{ cannot be negative!}).$$

So

$$\theta(z, t) = \theta_0 + Ae^{-Cz} \cos(\omega t - Cz)$$

It is slightly more convenient to rewrite this in the form

$$\theta(z, t) = \theta_0 + Ae^{-z/D} \cos(\omega t - \frac{z}{D})$$

where  $D = \frac{1}{C} = \sqrt{\frac{2k}{\omega}}$ . As in (i) we have  $A = 20$ .

Using the known values of  $k$  and  $w$ ,  $D = 0.12$  m (to 2 significant figures). The variation in temperature with depth  $z$  is  $40e^{-z/D}$ . This is less than 0.5 when  $z > D \ln(80) = 0.526$  m, or 0.53 m to two significant figures. So the roof of the wine cellar should be at a depth of at least 53 cm.

### Interpretation and Comment

The assumption that zero time corresponds to the highest temperature will not affect the variation at a particular depth, though it will affect its timing. However the assumption that the temperature at the surface is given by a cosine function is simple but not very realistic. It is possible to derive the result of using a more sophisticated model from that of the simple one by means of Fourier series. Suppose that the surface temperature is given by  $\theta(0, t) = f(t)$  for  $-12 \leq t \leq 12$  ( $t$  in hours). The daily variation is not far from a triangular wave form, given by  $A + B|t|$ , for appropriate constants  $A$  and  $B$ . On the interval  $(-12, 12)$  the function  $f(t) = \frac{10}{3}(12 - |t|)$ , has the correct shape and amplitude. If  $f$  is an even function it can be represented by a sum of cosines, i.e.

$$f(t) = \frac{1}{2}a_0 + \sum_{n=1}^{\infty} a_n \cos\left(\frac{n\pi t}{12}\right) \quad (6)$$

where

$$a_n = \frac{1}{12} \int_{-12}^{12} f(s) \cos\left(\frac{n\pi s}{12}\right) ds \quad (n = 0, 1, 2, 3, \dots)$$

This is the Fourier series on  $(-a, a)$  with  $a = 12$ .

Using (6),

$$f(t) = \frac{10}{3}(12 - |t|) = 20 + \sum_{n=1}^{\infty} \frac{160}{(2n-1)^2\pi^2} \cos\left(\frac{(2n-1)\pi t}{12}\right).$$

With  $\omega = (2n-1)\frac{\pi}{12}$ , the corresponding solution to give  $A \cos \frac{(2n-1)\pi t}{12}$  at the surface is

$$\theta_n(z, t) = A \exp\left(-\frac{z\sqrt{2n-1}}{D}\right) \cos\left(\frac{(2n-1)\pi t}{12} - \frac{z\sqrt{2n-1}}{D}\right)$$

where  $D = \sqrt{\frac{24k}{\pi}} < 0.12$  m as before. The solutions corresponding to the terms which sum to give  $\frac{10}{3}(12 - |t|)$  are summed to give

$$20 + \sum_{n=1}^{\infty} \frac{160}{(2n-1)^2\pi^2} \exp\left(-\frac{z\sqrt{2n-1}}{D}\right) \cos\left(\frac{(2n-1)\pi t}{12} - \frac{z\sqrt{2n-1}}{D}\right)$$

This function satisfies (1) and has the value  $\frac{10}{3}(12 - |t|)$  at  $z = 0$ . Note that the highest values of the exponential terms fall off rapidly as  $z$  increases and are at most  $e^{-z/D}$  so the total variation in temperature is at most  $2 \sum_{n=1}^{\infty} \frac{160}{(2n-1)^2\pi^2} e^{-z/D}$ .

Now putting  $t = 12$  and  $z = 0$  shows that

$$20 - \sum_{n=1}^{\infty} \frac{160}{(2n-1)^2\pi^2} = \theta(0, 12) = 0, \quad \text{so} \quad \sum_{n=1}^{\infty} \frac{160}{(2n-1)^2\pi^2} = 20$$

This means that the maximum variation is  $40e^{-z/D}$  as for the simple model, so the depth of 0.53 m deduced with the simple model will suffice. If a better estimate is obtained by isolating the first variable term and showing that all the other exponential terms are at most  $e^{-z\sqrt{3}/D}$  it is found that a very slightly smaller depth will suffice.

### **Interpretation**

In summary, using a more sophisticated model for the surface temperature variation than (2) and expressing  $f$  as a Fourier series results in the conclusion that same depth will suffice for the wine cellar.

## Two-dimensional flow past a cylindrical obstacle

### Mathematical Skills

Topic	Workbook
Algebra - rearranging formulae	[1]
Trigonometry	[4]
Polar coordinate system	[17], [28]

### Introduction

Many investigations in engineering fluid mechanics involve predicting the flow of fluid past obstacles and the forces involved on the solid boundary. For example it is necessary to calculate the aerodynamic forces on an aircraft (the lift and drag), the wind loading on buildings and the drag on all types of land vehicles. In water it is necessary to calculate the hydrodynamic forces on boats or on bridge supports. Modelling fluid flow past obstacles uses the concepts of **streamlines** and **stream functions** ( $\psi$ ). Streamlines are lines of constant  $\psi$ . A set of streamlines in a given region of space represents the **velocity field**. On the boundary of a solid obstacle, the stream function is constant.

In polar coordinates  $(r, \theta)$ , examples of stream functions used in modeling flow are (a)  $Ur \sin \theta$  for a uniform flow parallel to the  $x$ -axis where  $U$  is the magnitude of the flow velocity and (b)  $2am \sin \theta/r$  for a **dipole** consisting of a **source** and **sink** of equal strength  $2\pi m$  at equal distances  $a$  either side of the coordinate origin (shown with Cartesian coordinates  $(-a, 0)$  and  $(a, 0)$  respectively in Figure 18.1).

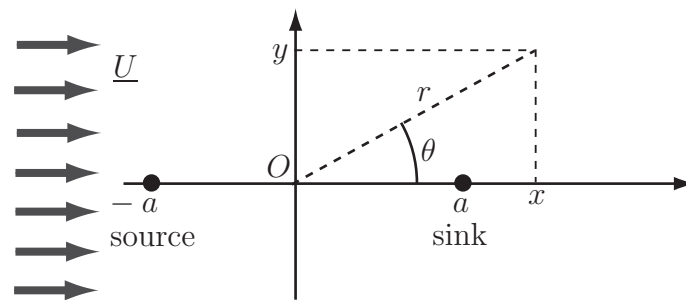

**Figure 18.1:** Geometry of the dipole (source and sink) and coordinate system

For many problems it is assumed that

- (i) The fluid flowing past the obstacle is incompressible and inviscid (no friction)
- (ii) The flow is steady (constant in time).

The principle of superposition (due to Rankine) enables the addition of the stream functions of superimposed velocity fields. For example, the superposition of a steady uniform flow and the flow due to a dipole is represented by the sum of the respective stream functions:

$$\psi = Ur \sin \theta - 2am \sin \theta/r.$$



### Problem in words

Show that the stream function resulting from the sum of the stream functions for a uniform flow and for a dipole can be used to represent flow past a rigid cylinder of given radius. Find the value of source strength  $m$  that ensures this.

### Mathematical statement of problem

Calculate points on streamlines  $\psi = 0$  and  $\psi = \pm Ua$  based on the combined stream function

$$\psi = Ur \sin \theta - 2am \sin \theta / r.$$

Show that part of the streamline  $\psi = 0$  is a circle coincident with the cylinder boundary with radius  $a$ , and deduce the implied value of  $m$  related to the source strength of the dipole.

### Mathematical analysis

The factor  $\sin \theta$  can be taken outside a bracket in the combined stream function  $\psi$  so that

$$\psi = \sin \theta \left( \frac{Ur^2 - 2am}{r} \right). \quad (1)$$

If  $\psi = 0$ , then

$$\sin \theta \left( \frac{Ur^2 - 2am}{r} \right) = 0.$$

For this to be true then either (i)  $\sin \theta = 0$  or (ii)  $\frac{Ur^2 - 2am}{r} = 0$ .

(i) If  $\sin \theta = 0$ , then  $\theta = 0$  or  $\pi$ .

(ii) If  $\frac{Ur^2 - 2am}{r} = 0$ , then  $Ur^2 - 2am = 0$  which implies

$$r = \sqrt{\frac{2am}{U}}. \quad (2)$$

Since  $a$ ,  $m$  and  $U$  are constants, (2) defines a circle of radius  $\sqrt{\frac{2am}{U}}$ .

Consequently, the streamline  $\psi = 0$  has three parts:

(I) points satisfying the condition  $\theta = \pi$ , i.e. along the negative  $x$ -axis,

(II) points satisfying the condition  $\theta = 0$ , i.e. the positive  $x$ -axis,

(III) points on a circle of radius  $\sqrt{\frac{2am}{U}}$ .

Assuming that the cylinder has a radius  $a$  equal to the distance of the source or sink term in the dipole from the coordinate origin, it is possible to choose

$$a = \sqrt{\frac{2am}{U}} \quad (3)$$

This ensures that the circular boundary of the rigid cylinder is part of the streamline  $\psi = 0$ . No flow may cross a streamline so a solid boundary is always part of a streamline of the flow. There are no streamlines inside the circular cross section of the cylinder, therefore the streamlines for  $-a \leq x \leq a$  and  $-a \leq y \leq a$  which would be inside the circular cross section of the cylinder are not shown in Figure 18.2.

Equation (3) implies that the source strength has a value given by  $m = \frac{aU}{2}$ .

With this value of  $m$ , the stream function defined in (1) becomes

$$\psi = U \sin \theta \left( \frac{r^2 - a^2}{r} \right). \quad (4)$$

Now consider the streamline  $\psi = Ua$ . From (4), this means that

$$Ua = U \sin \theta \left( \frac{r^2 - a^2}{r} \right)$$

which can be written as

$$a = r \sin \theta \left( 1 - \frac{a^2}{r^2} \right). \quad (5)$$

It is easier to plot the associated streamlines if (5) is expressed in terms of Cartesian coordinates  $(x, y)$ . Using  $y = r \sin \theta$  and  $r = \sqrt{x^2 + y^2}$  (see Figure 18.1), Equation (5) gives

$$\frac{y}{a} = \frac{1}{1 - \frac{a^2}{x^2 + y^2}}. \quad (6)$$

This can be written as  $\frac{y}{a} = \frac{x^2 + y^2}{x^2 + y^2 - a^2}$  or  $\frac{y}{a} (x^2 + y^2 - a^2) = x^2 + y^2$ .

In this case the algebra is easier if  $\frac{x}{a}$  is expressed in terms of  $\frac{y}{a}$  instead of the other way round, which is more usual. Dividing through by  $ay$  leads to

$$\frac{x^2}{a^2} + \frac{y^2}{a^2} - 1 = \frac{x^2}{ay} + \frac{y}{a}.$$

Rearranging to get all the  $y$  terms on the left-hand side and  $x$  terms on the right-hand side requires three steps:

### Step 1

$$\left( \frac{y}{a} \right)^2 - \frac{y}{a} - 1 = \left( \frac{x}{a} \right)^2 \left( \frac{1}{\frac{y}{a}} - 1 \right),$$

### Step 2

$$\left\{ \frac{\left( \frac{y}{a} \right)^2 - \left( \frac{y}{a} \right) - 1}{1 - \left( \frac{y}{a} \right)} \right\} \times \left( \frac{y}{a} \right) = \left( \frac{x}{a} \right)^2.$$

### Step 3

$$\frac{x}{a} = \pm \sqrt{\left\{ \frac{-\left( \frac{y}{a} \right)^2 + \frac{y}{a} + 1}{\frac{y}{a} - 1} \right\} \times \left( \frac{y}{a} \right)}. \quad (7)$$

The plus and minus signs allow representation of the whole streamline for positive and negative values of  $x$ . Equation (7) is physically meaningful for  $\frac{y}{a} \neq 1$  and as long as the square root is real, i.e. for

$$\left\{ \frac{-\left(\frac{y}{a}\right)^2 + \frac{y}{a} + 1}{\frac{y}{a} - 1} \right\} \times \left(\frac{y}{a}\right) \geq 0 \quad (8)$$

First we look at the quadratic term

$$-\left(\frac{y}{a}\right)^2 + \frac{y}{a} + 1, \quad (9)$$

to determine where it changes sign. Using the quadratic formula with  $\frac{y}{a}$  as the variable, the roots of

(9) are  $\frac{1 \pm \sqrt{5}}{2}$ .

So  $-\left(\frac{y}{a}\right)^2 + \frac{y}{a} + 1 \geq 0$  for  $\frac{1 - \sqrt{5}}{2} \geq \frac{y}{a} \geq \frac{1 + \sqrt{5}}{2}$ , (see Figure 18.2).

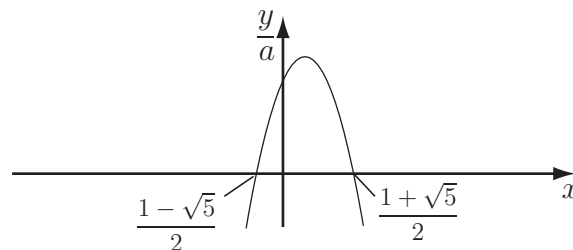

**Figure 18.2**

The first three lines of Table 1 show the signs of the terms on the left-hand side of (8) and allow us to deduce the range of values of  $\frac{y}{a}$  satisfying (8). The overall sign is shown in the last column of Table

1. So it can be concluded that Equation (8) is satisfied for  $\frac{1 - \sqrt{5}}{2} \leq \frac{y}{a} \leq 0$  and  $1 \leq \frac{y}{a} \leq \frac{1 + \sqrt{5}}{2}$ .

**Table 1: Signs of the terms in inequality (8)**

	$\frac{y}{a}$	$\frac{y}{a} - 1$	$-\left(\frac{y}{a}\right)^2 + \frac{y}{a} + 1$	$\frac{-\left(\frac{y}{a}\right)^2 + \frac{y}{a} + 1}{\frac{y}{a} - 1} \times \left(\frac{y}{a}\right)$
$-\infty < \frac{y}{a} < \frac{1 - \sqrt{5}}{2}$	negative	negative	negative	negative
$\frac{1 - \sqrt{5}}{2} \leq \frac{y}{a} \leq 0$	negative	negative	positive	positive
$0 < \frac{y}{a} < 1$	positive	negative	positive	negative
$1 \leq \frac{y}{a} \leq \frac{1 + \sqrt{5}}{2}$	positive	positive	positive	positive
$\frac{1 + \sqrt{5}}{2} < \frac{y}{a} < +\infty$	positive	positive	negative	negative

The scaled coordinates,  $\frac{x}{a}$  and  $\frac{y}{a}$ , give results that are independent of the values of  $a$ .

Now consider the streamline  $\psi = -Ua$ , Equation (4) leads to  $-Ua = U \sin \theta \left( \frac{r^2 - a^2}{r} \right)$  which, after using  $y = r \sin \theta$  and  $r = \sqrt{x^2 + y^2}$ , as for  $\psi = +Ua$ , can be written as

$$\frac{y}{a} = \frac{-1}{1 - \frac{a^2}{x^2 + y^2}}. \quad (10)$$

Equation (10) is simply the negative of (6). Therefore, without further algebraic effort it can be deduced that the streamline  $\psi = -Ua$  is symmetrical to the streamline  $\psi = Ua$  with respect to the  $\frac{y}{a} = 0$  axis.

The streamlines  $\psi = 0$  and  $\psi = \pm Ua$  are plotted in Figure 18.3. As a result of the choice of scaled Cartesian coordinates,  $\frac{x}{a}$  and  $\frac{y}{a}$ , the cylinder has a radius 1.

### Interpretation

The streamlines  $\psi = 2Ua$  and  $\psi = -2Ua$  are also shown in Figure 18.3. They are similar to the streamlines  $\psi = Ua$  and  $\psi = -Ua$  but are at roughly twice the distance from the  $x$ -axis. Fluid particles approaching the cylinder along parallel straight lines aligned with the  $x$ -axis are deflected around the cylinder. The amount of their deflection increases as the streamline approaches the  $x$ -axis. This is consistent with intuition about the motion of fluid particles constrained to flow around a cylindrical obstacle. The streamlines are also in very good agreement with observations except immediately in front of the cylinder and behind the cylinder where the assumption of steady flow does not hold.

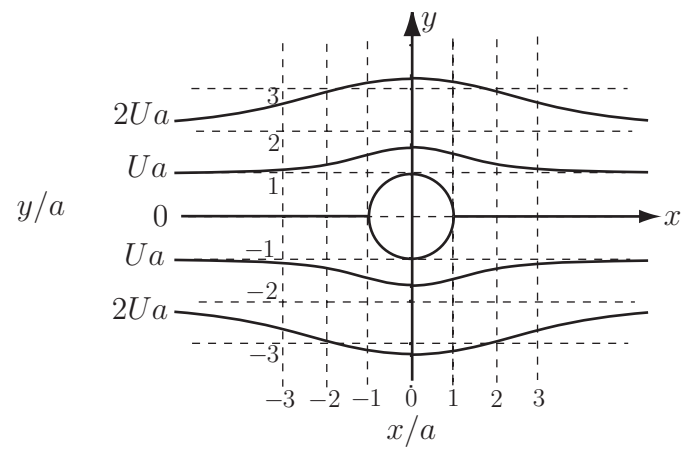

**Figure 18.3:** Streamlines generated by constant values of the stream function



# Engineering Case Study 19

## Two-dimensional flow of a viscous liquid on an inclined plate

### Mathematical Skills

Topic	Workbook
Trigonometry	[4]
Integration	[13]
Polar coordinate system	[17], [28]
Partial differentiation	[18]
Partial differential equations	[25]
Vector calculus	[28]
Dimensional analysis	[47]

### Introduction

Many investigations in engineering fluid mechanics involve predicting the flow of liquids in channels or pipes. Simple models assume that the liquid is inviscid i.e. that it is not viscous. However, d'Alembert's paradox and other results for inviscid flow show that the inviscid fluid flow model needs to be refined by the introduction of viscous forces. The modelling of inviscid fluid flows uses Euler's equation of motion based on the assumption that surface forces on a fluid element are only normal to the surface of the fluid element. Tangential forces due to viscosity are ignored. The Navier-Stokes equation of fluid flow is a generalisation of Euler's equation to include viscous forces. In Cartesian coordinates the equation can be written

$$\rho \frac{d\mathbf{u}}{dt} = -\nabla p + \rho \mathbf{F} + \mu \nabla^2 \mathbf{u} \quad (1)$$

where  $\mu$  is the coefficient of viscosity,  $\rho$  is the fluid density,  $p$  is the pressure,  $\mathbf{F}$  is the body force per unit mass and  $\mathbf{u}$  represents the fluid velocity. Note that the total time derivative operator is defined as  $\frac{d}{dt} \equiv \frac{\partial}{\partial t} + \mathbf{u} \cdot \nabla$ .

For many problems it is assumed that

- (i) The fluid is incompressible
- (ii) The fluid is Newtonian (stress proportional to the rate of deformation)
- (iii) The fluid has constant viscosity
- (iv) The flow is fully-developed (the flow is identical at all points of a fluid element trajectory for a given time)

### Problem in words

Find the velocity distribution in a viscous liquid flowing freely and steadily under gravity over a very large inclined plate when the liquid is subjected to a shear stress of known value as a result of air blown across its surface. Sketch a graph of the velocity profile for positive, negative and vanishing shear stress in dimensionless form.

**Mathematical statement of problem**

Choose the direction of the flow as the  $x$ -axis, the normal to the liquid/air interface and to the plate as the  $z$ -axis (see Figure 19.1), so the  $y$ -axis is chosen to lie along the plate. Assume that the plate is infinitely large along the  $y$ -axis. The flow is modelled as two-dimensional i.e. there is zero velocity in the  $y$ -direction. Consequently, defining  $\underline{u} = u_x \underline{i} + u_y \underline{j} + u_z \underline{k}$  as the velocity vector in the orthonormal basis set  $(\underline{i}, \underline{j}, \underline{k})$ ,

- (i)  $u_y = 0$
- (ii) the derivatives with respect to variable  $y$  are zero.

The flow is steady, therefore

- (iii) the derivatives with respect to time are zero.

The flow is fully developed in the direction of the flow, therefore

- (iv) the derivatives with respect to variable  $x$  are zero.

**(I)** Write down the boundary conditions at  $z = 0$  and  $z = l$  that must be satisfied by  $\underline{u}$  using conditions (i)-(iv).

**(II)** Apply the continuity equation  $\nabla \cdot \underline{u} = 0$ .

**(III)** Apply the Navier-Stokes equation (1) to the flow conditions (i)-(iv) and integrate to find the velocity distribution.

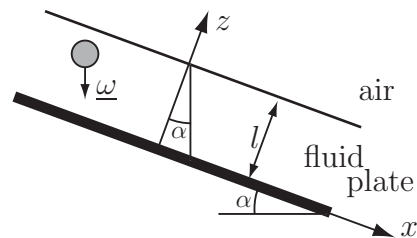

**Figure 19.1:** Geometry of the flow and coordinate system

### Mathematical analysis

(I) The boundary condition at  $z = 0$  is that  $\underline{u} = \underline{0}$  as the plate is at rest and is assumed that there is no slip between the liquid and the plate. This means that  $u_x|_{z=0} = 0$  and  $u_z|_{z=0} = 0$ .

The boundary condition at  $z = l$  relates the given shear stress  $T$  generated by the air flow to the velocity i.e.

$$T = \mu \frac{\partial u_x}{\partial z} \Big|_{z=l}. \quad (2)$$

(II) The continuity equation  $\nabla \cdot \underline{u} = 0$  can be written in Cartesian coordinates as

$$\frac{\partial u_x}{\partial x} + \frac{\partial u_y}{\partial y} + \frac{\partial u_z}{\partial z} = 0. \quad (3)$$

Conditions (i) and (iv) simplify (3) as

$$\frac{\partial u_z}{\partial z} = 0. \quad (4)$$

(III) Using the definitions of  $\nabla$  and  $\nabla^2$  in Cartesian coordinates given in HELM 28.2, the Navier-Stokes equation (1) can be written as the three equations

$$\rho \left( \frac{\partial u_x}{\partial t} + u_x \frac{\partial u_x}{\partial x} \right) = -\frac{\partial p}{\partial x} + \rho F_x + \mu \left( \frac{\partial^2 u_x}{\partial x^2} + \frac{\partial^2 u_x}{\partial y^2} + \frac{\partial^2 u_x}{\partial z^2} \right) \quad (5)$$

$$\rho \left( \frac{\partial u_y}{\partial t} + u_y \frac{\partial u_y}{\partial y} \right) = -\frac{\partial p}{\partial y} + \rho F_y + \mu \left( \frac{\partial^2 u_y}{\partial x^2} + \frac{\partial^2 u_y}{\partial y^2} + \frac{\partial^2 u_y}{\partial z^2} \right) \quad (6)$$

$$\rho \left( \frac{\partial u_z}{\partial t} + u_z \frac{\partial u_z}{\partial z} \right) = -\frac{\partial p}{\partial z} + \rho F_z + \mu \left( \frac{\partial^2 u_z}{\partial x^2} + \frac{\partial^2 u_z}{\partial y^2} + \frac{\partial^2 u_z}{\partial z^2} \right) \quad (7)$$

corresponding to projections on the three Cartesian axes. The body force in this problem is due to gravity, therefore,  $F_x = g \sin \alpha$ ,  $F_y = 0$  and  $F_z = g \cos \alpha$  where  $\alpha$  is the inclination angle of the plate to the horizontal. Conditions (i) to (iv) enable simplification of (5) to (7) respectively as

$$0 = \rho F_x + \mu \frac{\partial^2 u_x}{\partial z^2} \quad (8)$$

$$0 = 0 \quad (9)$$

$$\rho u_z \frac{\partial u_z}{\partial z} = -\frac{\partial p}{\partial z} + \rho F_z + \mu \frac{\partial^2 u_z}{\partial z^2}. \quad (10)$$

Using (4), Equation (10) becomes

$$0 = -\frac{\partial p}{\partial z} + \rho F_z. \quad (11)$$

The coefficient of viscosity and the liquid density are constant, and (8) can be integrated over variable  $z$  to find the velocity profile.

Integration from  $l$  to  $z$  gives  $\mu \int_l^z \frac{\partial^2 u_x}{\partial z^2} dz = -\rho \int_l^z F_x dz$ .

The  $x$ -component of the body force  $F_x = g \sin \alpha$  does not depend on  $z$  and can be taken out of the integral. So

$$\begin{aligned} \mu \left[ \frac{\partial u_x}{\partial z} \right]_l^z &= -\rho F_x \int_l^z dz, \text{ or} \\ \mu \left[ \frac{\partial u_x}{\partial z} - \frac{\partial u_x}{\partial z} \Big|_{z=l} \right] &= -\rho F_x (z - l). \end{aligned} \quad (12)$$



Using boundary condition (2), (12) may be rewritten as

$$\mu \left[ \frac{\partial u_x}{\partial z} - \frac{T}{\mu} \right] = -\rho F_x (z - l). \quad (13)$$

Note that the integration was chosen from  $l$  to  $z$  in order to use the (2) at this stage. Integrating one more time over variable  $z$  starting from (13) leads to

$$\mu \int_0^z \left[ \frac{\partial u_x}{\partial z} - \frac{T}{\mu} \right] dz = -\rho F_x \int_0^z (z - l) dz,$$

where the integration bounds have been chosen from 0 to  $z$  in order to use the boundary condition at  $z = 0$ . After evaluating the integrals

$$\mu (u_x(z) - u_x|_{z=0}) - Tz = -\rho F_x \left( \frac{z^2}{2} - lz \right). \quad (14)$$

The boundary condition at  $z = 0$  gave  $u_x|_{z=0} = 0$  therefore (14) leads to

$$u_x(z) = -\frac{\rho F_x}{2\mu} z^2 + \frac{T + \rho F_x l}{\mu} z. \quad (15)$$

The dimensions of  $\mu$  are  $ML^{-1}T^{-1}$ . (See HELM 47.1 for a discussion of dimensional analysis). So the dimensions of  $\frac{\rho F_x}{\mu}$  are  $ML^{-3}LT^{-2}/(ML^{-1}T^{-1}) = T^{-1}L^{-1}$  which is the same as the dimension of velocity divided by length squared. So dimensionless velocity  $u'_x$  is obtained by dividing (15) through by  $\frac{\rho F_x}{\mu} l^2$ . Furthermore if the variable  $z$  is scaled by  $l$  to yield a dimensionless (length) variable also then

$$u'_x \left( \frac{z}{l} \right) = -\frac{1}{2} \left( \frac{z}{l} \right)^2 + \left( \frac{T + \rho F_x l}{\rho F_x l} \right) \frac{z}{l}. \quad (16)$$

Examples of velocity profiles  $u'_x(z)$  for positive and zero values of shear stress are sketched in Figure 19.2 as the thin solid curve and dotted curve. Two velocity profiles are shown as the thick solid curve and dashed curve for negative values of shear stress. Note that  $z/l$  is plotted against  $u'_z$  so that when the liquid layer is superimposed on the velocity profile it is represented by the area between the pair of parallel thick horizontal black lines. The thickness of the liquid layer is 1 as a result of the scaling  $z/l$ .

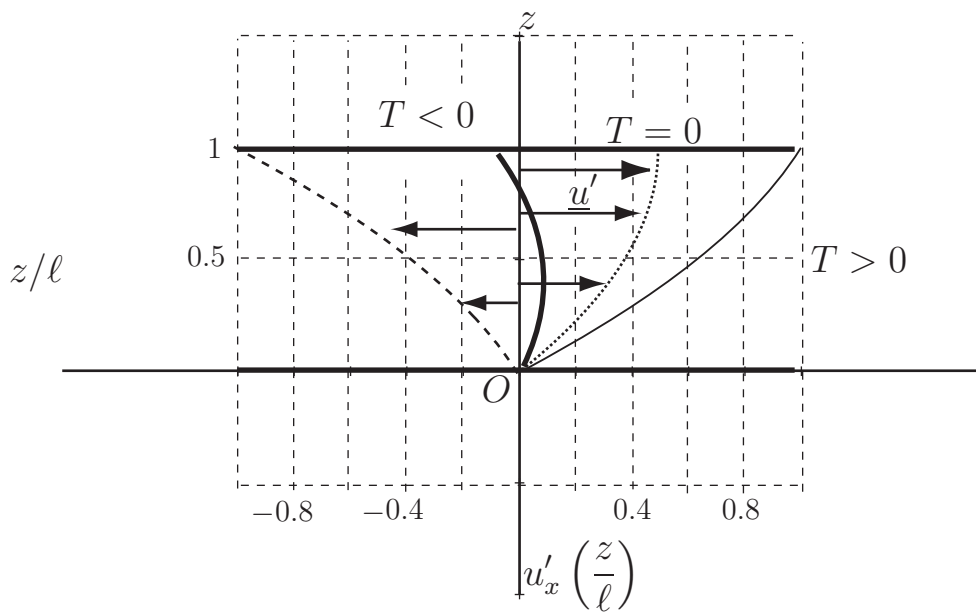

**Figure 19.2:** Dependence of velocity profile on shear stress

### Interpretation

When no air flow is present, the shear stress vanishes ( $T = 0$ ) and the liquid velocity magnitude increases from the bottom plate to the surface following a parabolic curve as expected (dotted curve). When air blows over the liquid in the direction of the flow and results in a positive shear stress ( $T > 0$ ), the magnitude of the liquid velocity is increased everywhere compared to the case with no air flow. Moreover the liquid velocity magnitude increases from the bottom plate to the surface following a parabolic curve (thin solid curve). When the air flow is in the opposite direction to the liquid flow, it results in a negative shear stress ( $T < 0$ ). Consequently, the liquid velocity magnitude is decreased when compared to the case with no air flow. If the shear stress is sufficient, the liquid at and near the surface may flow uphill as shown by the negative portion of the thick solid curve. The dashed curve shows results where the wind is so strong that whole of the liquid layer is pushed uphill with a speed that increases with height in the liquid layer. Note that the model for inviscid liquid in which tangential shear stresses are neglected results in a constant rather than parabolic velocity profile for flow on a plate.



# Engineering Case Study 20

## Force on a cylinder due to a two-dimensional streaming and swirling flow

### Mathematical Skills

Topic	Workbook
Trigonometry	[4]
Logarithmic functions	[6]
Integration	[13]
Orthogonality relations of trigonometric functions	[13]
Polar coordinate system	[17], [28]
Partial derivatives	[18]
Surface integrals	[29]

### Introduction

Many investigations in engineering fluid mechanics involve predicting the flow of fluid past obstacles and the forces involved on the solid boundary. For example it is necessary to calculate the aerodynamic forces on an aircraft (the lift and drag) on buildings subject to wind loading and on all types of land vehicles. In water it is necessary to calculate the hydrodynamic forces on boats or on bridge supports. Models of fluid flow past obstacles, i.e. **streaming flow** use the concepts of **streamlines** and **stream functions**  $\psi$ . Streamlines are lines of constant  $\psi$ . (See Engineering Case Study 18 Figure 18.3.) A set of streamlines in a given region of space represents the **velocity field**.

From Engineering Case Study 18 the stream function

$$\psi_1 = U \sin \theta \left( \frac{r^2 - a^2}{r} \right) \quad (1)$$

represents the flow in the  $x$ - $y$  plane past an infinite cylinder with its axis in the  $z$ -direction (see Figure 20.1) where  $(r, \theta, z)$  are the polar coordinates in the reference frame  $(\hat{r}, \hat{\theta}, \hat{k})$ ,  $U$  is the magnitude of the incident uniform flow velocity parallel to the  $x$ -axis and  $a$  is the radius of the cylinder.

A swirling flow around a cylinder of axis  $z$  can be modelled by the stream function of a **line vortex** directed along the  $z$ -axis. A line vortex models a two-dimensional rotational motion where the vorticity is concentrated along an axis. The stream function  $\psi_2$  for a line vortex of strength  $\kappa$  is

$$\psi_2 = \frac{\kappa}{2\pi} \ln r + \text{constant}. \quad (2)$$

The corresponding streamlines are circles in the  $xy$  plane with centre at the origin. The constant in (2) is arbitrary and vanishes when taking the derivatives to obtain the velocity. In the case of the flow around a cylinder of radius  $a$ , it is convenient to choose the constant as  $\frac{-\kappa}{2\pi} \ln a$  so that  $\psi_2 = \frac{\kappa}{2\pi} \ln \left( \frac{r}{a} \right)$ . With this choice of constant, the boundary of the cylinder corresponds to the streamline  $\psi_2 = 0$ .

For many problems it is assumed that

- (i) The fluid flowing past the obstacle is incompressible and inviscid (no friction)

(ii) The flow is steady (constant in time)

If the flow is irrotational and no body force is present, Bernoulli's equation applied along any curve in the fluid is given by

$$P + \frac{\rho u^2}{2} = C \quad (3)$$

where  $P$  is the pressure,  $\rho$  is the fluid density,  $u$  is the speed of the fluid and  $C$  is a constant. If the flow is rotational, the curve has to be a streamline for (3) to be valid.

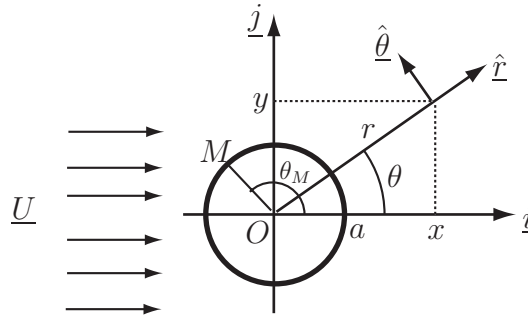

**Figure 20.1:** Geometry of the flow past the cylinder and coordinate systems

### Problem in words

Although the fluid is assumed to be inviscid, assume that friction at the boundary of the cylinder can cause fluid to swirl around the cylinder when it rotates around its axis. Find the net surface force on a cylinder in a two dimensional **swirling** flow of an inviscid, incompressible constant-density fluid. Show that a flow combining both **streaming** and **swirling** gives rise to lift.

### Mathematical statement of problem

(I) Using the stream function given by Equation (2), find the velocity field  $\underline{u} = u_r \hat{r} + u_\theta \hat{\theta}$  due to the line vortex by deriving the components  $u_r$  and  $u_\theta$  in a polar coordinate system. Use Bernoulli's equation (3) to deduce the pressure distribution  $P$  on the surface of the cylinder. The force corresponding to pressure  $P$  on a surface element  $dS$  is  $PdS$ . The total force  $\underline{F}$  on a surface is obtained by summing the effect of the fluid pressure  $P$  over all such surface elements i.e.

$$\underline{F} = - \int_S P \hat{n} dS \quad (4)$$

where  $\hat{n}$  is the unit normal to the surface element  $dS$  that is pointing into the fluid. Evaluate the  $x$ - and  $y$ -components of the force, i.e. the drag and lift respectively, on a unit length cylinder with its axis along the  $z$ -axis and deduce that the net surface force due to the line vortex is zero.

(II) Using (i) the velocity field obtained in the Engineering Example in HELM 28.3 for a flow streaming past a cylinder and (ii) the velocity field derived in (I), apply Bernoulli's Equation (3) to deduce the pressure distribution  $P$  on the surface of the cylinder. Find the  $x$  and  $y$  components of the force on a cylinder of unit length along the  $z$ -axis due to streaming flow and show that drag is zero but that the lift is not zero.

### Mathematical analysis

(I) The components of the velocity in polar coordinates in terms of the stream function  $\psi_2$  are

$$u_r = \frac{1}{r} \frac{\partial \psi_2}{\partial \theta} \quad (5)$$

and

$$u_\theta = -\frac{\partial\psi_2}{\partial r}. \quad (6)$$

Using (2) in (5) leads to  $u_r = \frac{1}{r} \frac{\partial}{\partial\theta} \left[ \frac{\kappa}{2\pi} \ln r + \text{constant} \right]$ , the term in the brackets does not depend on the variable  $\theta$ , therefore the derivative is zero and

$$u_r = 0. \quad (7)$$

Similarly, using (2) in (6),  $u_\theta = -\frac{\partial}{\partial r} \left[ \frac{\kappa}{2\pi} \ln r + \text{constant} \right]$ , and  $\frac{\partial}{\partial r}(\ln r) = \frac{1}{r}$ , so

$$u_\theta = -\frac{\kappa}{2\pi r}. \quad (8)$$

Applying Bernoulli's equation (3) at a point  $M(a, \theta_M)$  on the surface of the cylinder shown in Figure 20.1 leads to

$$P + \frac{\rho \left( -\frac{\kappa}{2\pi a} \right)^2}{2} = C \quad \text{so}$$

$$P = C - \frac{\rho\kappa^2}{8\pi^2 a^2}. \quad (9)$$

Note that the surface of the cylinder is a streamline and that Bernoulli's equation (3) can be applied at all points of the surface. The general expression of the force over the whole surface is given by Equation (4). The surface to be considered is that of an idealised cylinder of infinite length along the  $z$ -axis. Consequently, the unit normal to the surface element  $dS$ ,  $\hat{n}$ , which is pointing into the fluid, is

$$\hat{n} = \hat{r} = \underline{i} \cos \theta + \underline{j} \sin \theta. \quad (10)$$

Rather than computing the force on a cylinder of infinite length, consider a unit length cylinder with its axis along the  $z$ -axis. The surface element becomes  $dS = a d\theta \times 1$  and use of (4) with (10) gives  $\underline{F} = - \int_0^{2\pi} P(\underline{i} \cos \theta + \underline{j} \sin \theta) a d\theta$ , since the integral over the whole cylindrical surface  $S$  requires that the variable  $\theta$  runs from 0 to  $2\pi$ .

The force can be decomposed into  $x$ - and  $y$ -components:

$$x\text{-component:} \quad F_{\text{drag}} = -a \int_0^{2\pi} P \cos \theta d\theta \quad (11)$$

and

$$y\text{-component:} \quad F_{\text{lift}} = -a \int_0^{2\pi} P \sin \theta d\theta. \quad (12)$$

Note that the basis vectors  $\underline{i}$  and  $\underline{j}$  are constant and can be taken out of these integrals. Using Equations (11) and (12) and the expression for pressure given by (9),

$$F_{\text{drag}} = - \left( C - \frac{\rho\kappa^2}{8\pi^2 a^2} \right) a \int_0^{2\pi} \cos \theta d\theta \quad (13)$$

and

$$F_{\text{lift}} = - \left( C - \frac{\rho\kappa^2}{8\pi^2 a^2} \right) a \int_0^{2\pi} \sin \theta d\theta \quad (14)$$

(As the pressure does not depend on the polar angle it can be taken out of the integral.) The integrals can be evaluated as

$$\int_0^{2\pi} \cos \theta \, d\theta = \left[ \sin \theta \right]_0^{2\pi} = 0 \quad (15a)$$

and

$$\int_0^{2\pi} \sin \theta \, d\theta = - \left[ \cos \theta \right]_0^{2\pi} = 0. \quad (15b)$$

Using (15a) and (15b) in (13) and (14), we conclude that  $F_{\text{drag}} = 0$  and  $F_{\text{lift}} = 0$ .

Therefore, the net surface force on a cylinder in a **swirling** flow is zero. Note also that the net surface force on a cylinder in a **streaming** flow is zero.

The next section shows that a combination of streaming and swirling flow gives rise to a non-zero surface force but before proceeding we will develop solutions to six integrals that we shall need.

## Useful integration results

In HELM 13.6 three 'orthogonality relations' were introduced (pages 52-54). Two of these can be summarised as follows:

For any integers  $m$  and  $n$ :

$$I_{m,n} \equiv \int_0^{2\pi} \sin mx \sin nx \, dx = \begin{cases} 0 & (m \neq n) \\ 0 & (m = n = 0) \\ \pi & (m = n \neq 0) \end{cases}$$

$$K_{m,n} \equiv \int_0^{2\pi} \sin mx \cos nx \, dx = 0 \quad (\text{in all cases})$$

We will now use these orthogonality relations, along with the two identities

$$\cos 2\theta \equiv 1 - 2\sin^2 \theta \quad (\text{so } \sin^2 \theta \equiv \frac{1 - \cos 2\theta}{2})$$

$$\sin 2\theta \equiv 2\sin \theta \cos \theta \quad (\text{so } \sin \theta \cos \theta \equiv \frac{\sin 2\theta}{2})$$

to evaluate six integrals needed in future calculations.

$$\int_0^{2\pi} \sin \theta \, d\theta = I_{1,0} = 0 \tag{16a}$$

$$\int_0^{2\pi} \cos \theta \, d\theta = K_{0,1} = 0 \tag{16b}$$

$$\int_0^{2\pi} \sin \theta \cos \theta \, d\theta = K_{1,1} = 0 \tag{16c}$$

$$\int_0^{2\pi} \sin^2 \theta \, d\theta = \int_0^{2\pi} \sin \theta \sin \theta \, d\theta = I_{1,1} = \pi \tag{16d}$$

$$\int_0^{2\pi} \sin^2 \theta \cos \theta \, d\theta = \int_0^{2\pi} \sin \theta \sin \theta \cos \theta \, d\theta = \int_0^{2\pi} \sin \theta \frac{\sin 2\theta}{2} \, d\theta = \frac{1}{2} I_{1,2} = 0 \tag{16e}$$

$$\begin{aligned} \int_0^{2\pi} \sin^3 \theta \, d\theta &= \int_0^{2\pi} \sin \theta \left( \frac{1 - \cos 2\theta}{2} \right) \, d\theta = \frac{1}{2} \int_0^{2\pi} \sin \theta \, d\theta - \frac{1}{2} \int_0^{2\pi} \sin \theta \cos 2\theta \, d\theta \\ &= \frac{1}{2} K_{1,0} - \frac{1}{2} K_{1,2} = 0 \end{aligned} \tag{16f}$$

[Note: other methods could be used to obtain these six results of course.]

(II) The components of the velocity field in polar coordinates for a streaming flow past a cylinder are derived from the stream function as

$$u_r^{\text{stream}} = U \cos \theta \left( \frac{r^2 - a^2}{r^2} \right) \quad (17)$$

and

$$u_\theta^{\text{stream}} = -U \sin \theta \left( \frac{r^2 + a^2}{r^2} \right). \quad (18)$$

Combining (17) and (18) with results (7) and (8) for the velocity field due to the line vortex obtained in part (I) gives

$$u_r = U \cos \theta \left( \frac{r^2 - a^2}{r^2} \right) \quad (19)$$

and

$$u_\theta = -U \sin \theta \left( \frac{r^2 + a^2}{r^2} \right) - \frac{\kappa}{2\pi r} \quad (20)$$

According to Bernoulli's equation (3), the pressure at a point  $M(a, \theta_M)$  on the surface of the cylinder shown in Figure 20.1 is

$$P = C - \frac{\rho u^2}{2} \quad (21)$$

where  $u^2 = u_r^2 + u_\theta^2$  at  $r = a$ .

Equations (19) and (20) with  $r = a$  give

$$u^2 = 4U^2 \sin^2 \theta + \frac{\kappa^2}{4\pi^2 a^2} + \frac{2U\kappa}{\pi a} \sin \theta \quad (22)$$

### Calculating $F_{\text{drag}}$

Using Equations (11), (21) and (22), the drag on the cylinder is given by

$$F_{\text{drag}} = -a \int_0^{2\pi} \left( C - \frac{\rho}{2} \left\{ 4U^2 \sin^2 \theta + \frac{\kappa^2}{4\pi^2 a^2} + \frac{2U\kappa}{\pi a} \sin \theta \right\} \right) \cos \theta \, d\theta.$$

The integral can be decomposed as the sum of three terms and the drag can be written as

$$F_{\text{drag}} = -a (I_1 + I_2 + I_3). \quad (23)$$

We will evaluate each of the component integrals in turn using the results (16a) to (16f).

$$I_1 \equiv \left( C - \frac{\rho \kappa^2}{8\pi^2 a^2} \right) \int_0^{2\pi} \cos \theta \, d\theta = 0 \quad (\text{using 16b})$$

$$I_2 \equiv -4\rho U^2 \int_0^{2\pi} \sin^2 \theta \cos \theta \, d\theta = 0 \quad (\text{using 16e})$$

$$I_3 \equiv -\frac{U\rho\kappa}{\pi a} \int_0^{2\pi} \sin \theta \cos \theta \, d\theta = 0 \quad (\text{using 16c})$$

So according to Equation (23),  $F_{\text{drag}} = 0$ .

There is no drag on the cylinder in a streaming and swirling flow.



### Calculating $F_{\text{lift}}$

Using Equations (12), (21) and (22), the lift on the cylinder is given by

$$F_{\text{lift}} = -a \int_0^{2\pi} \left( C - \frac{\rho}{2} \left\{ 4U^2 \sin^2 \theta + \frac{\kappa^2}{4\pi^2 a^2} + \frac{2U\kappa}{\pi a} \sin \theta \right\} \right) \sin \theta \, d\theta$$

The integral can be expressed as the sum of three terms i.e.

$$F_{\text{lift}} = -a (I_4 + I_5 + I_6) \quad (24)$$

Again, each of the component integrals may be evaluated in turn.

$$I_4 \equiv \left( C - \frac{\rho\kappa^2}{8\pi^2 a^2} \right) \int_0^{2\pi} \sin \theta \, d\theta = 0. \quad (\text{using 16a})$$

$$I_5 \equiv -2\rho U^2 \int_0^{2\pi} \sin^3 \theta \, d\theta = 0 \quad (\text{using 16f})$$

$$I_6 \equiv -\frac{U\rho\kappa}{\pi a} \int_0^{2\pi} \sin^2 \theta \, d\theta = -\frac{U\rho\kappa}{a} \quad (\text{using 16d})$$

So Equation (24) means that the combination of streaming and swirling flow on a cylinder gives rise to a lift force,  $F_{\text{lift}} = U\rho\kappa$ .

### Interpretation

The conclusion that there is no drag on a cylinder in a streaming and swirling flow seems counter-intuitive and is called d'Alembert's paradox. Indeed, holding an object in the wind is an example showing that drag **is** present. In practice, real fluids are not inviscid and viscosity has to be introduced to model drag and resolve d'Alembert's paradox. Although no force is found on a cylinder in either streaming or swirling flow of an inviscid fluid, a lift is generated when such flows are combined. As long as the fluid is viscous, the swirling of fluid around a cylinder may be generated practically by the rotation of the cylinder since a viscous fluid is entrained by the cylinder and rotates with it. Such a rotating cylinder is subject to a lift when a fluid streams past it. This is called the Magnus effect and has been utilised to propel ships. Tall rotating cylinders called Flettner Rotors are mounted on their decks. The combination of wind and cylinder rotation gives a propulsive force at right-angles to the wind.