

CHEMTECH

The Innovator's Magazine SEPTEMBER 1988



Page 540

Grow carbon fibers in the vapor phase

What you can make out of these strong materials and how to make them.

Morinobu Endo

Carbon fiber based on rayon and on polyacrylonitrile (PAN) emerged splendidly as the "Rider of the New Industrial Revolution" in the early 1960s. Today the industry has a market volume of more than 3000 tons/year and is expanding into aerospace, automobile, and construction materials applications. At the same time, users are demanding carbon fiber with diversified properties and low cost, so R&D is competing fiercely for new types of carbon fiber. The newest of these are grown in the vapor phase.

Vapor-phase-grown carbon fiber (VGCF) is generally shorter than a few decimeters; unlike PAN-based and pitch-based continuous fiber, VGCF is discontinuous. In the future, discontinuous fiber such as chopped fiber (several millimeters or shorter) and milled fiber (150 μm) will be used to substitute for asbestos and as the reinforcing agent for automobile plastics and cement. Recent demands call for carbon fiber that has unique properties in addition to strength. VGCF has a high electrical conductivity so that it can be used as filler in electromagnetic shielding plastics and other conducting materials. Such functions are inconceivable for conventional fibers.

Recent industrial research has concentrated on the use of VGCF as the discontinuous fiber for carbon fiber reinforced polymers, carbon fiber reinforced metals, and carbon fiber reinforced ceramics so that production wastes and various hydrocarbons could be used to make industrially useful materials.

The history of carbon fibers goes back to 1890 (1). A number of researchers had found fine fibrous carbon, quite often by accident, in carbonaceous soot and films while studying the thermal decomposition of hydrocarbons such as methane and benzene and the

disproportionation of carbon monoxide. Such fibrous carbon did not attract much attention until the mid-1950s, when several important breakthroughs occurred. The proof by Herring and co-workers (2) that the strength of lead whiskers is close to its theoretical value excited interest in whiskers. Hillert and Lang (3) produced fibrous carbon (5 cm long, 200 μm in diameter) by heating nitrogen gas saturated with *n*-heptane at around 1000 °C in a quartz tube over iron or ceramic substrates. Meyer (4) obtained fibrous matter (1.3 mm long, 0.1 mm in diameter) by heating a carbon substrate to 2000 °C and passing over it hydrogen-diluted methane. The thermal decomposition of methane gave "carbon whiskers."

VGCFs are not single crystalline whiskers in the strict crystallographic sense; rather, the term emphasizes the engineering application of the "whiskers." Moreover, VGCFs resemble the structure and growth mechanism of single-crystal whiskers. In particular, the carbon fiber, when heated at 2800–3000 °C, is transformed from turbostratic carbon into graphite with a well-developed structure that at present is the closest to the graphite whiskers made by Bacon (5).

Fibrous carbon

Many of the early studies were directed toward the production and applications of such fibrous carbon but failed to determine the growth conditions and mechanisms involved, because results could not be repeated.

Figure 1 presents the two historic models proposed for carbon fiber growth: spiral growth, and a model in which carbon fiber, once formed over impurity particles on a substrate, continues to grow thereafter without any connection with impurity particles (3).

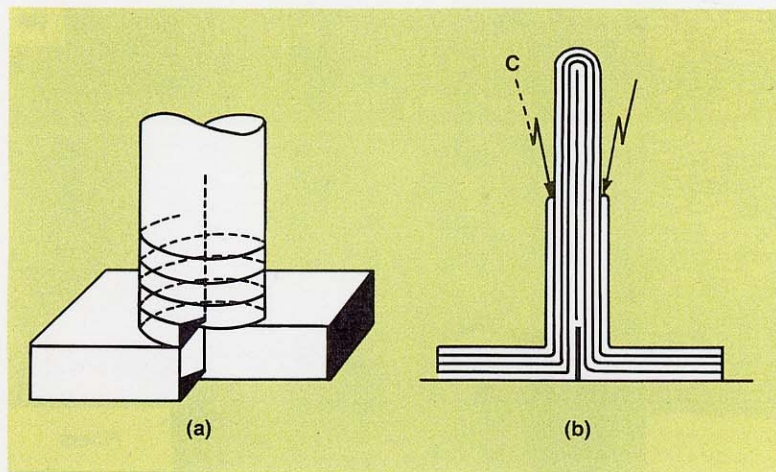

Figure 1. Historical growth models of carbon fiber from gas phase; (a) spiral model; (b) impurity model (3)

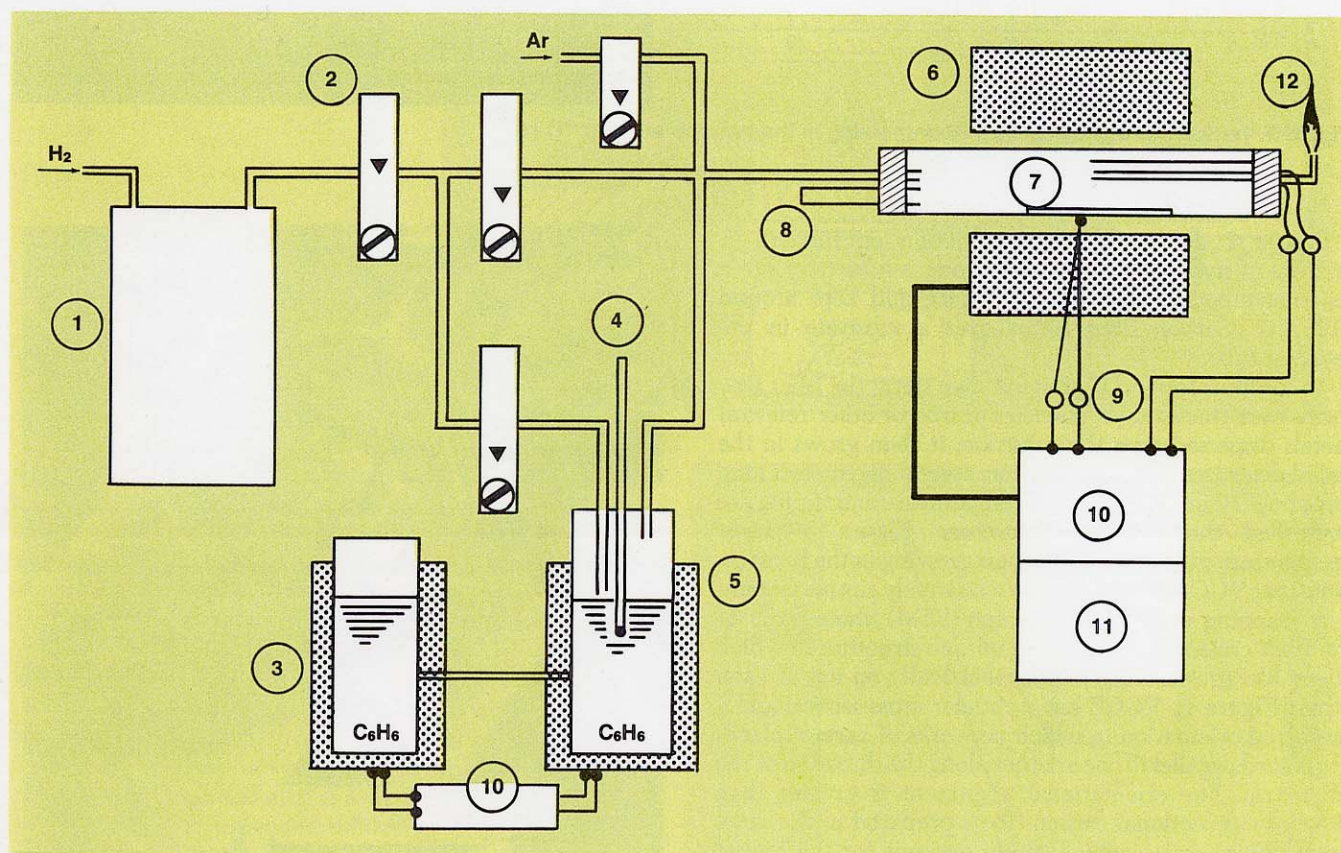

Figure 2. Equipment for production of VGCF. 1, hydrogen purification unit; 2, flowmeter; 3 and 5, benzene; 4, thermometer; 5, thermostatic bath; 6, electrical furnace; 7, substrate; 8, observation window; 9, thermocouples; 10 and 11, temperature controller and recorder; 12, gas exhaust

New electron microscopic analysis techniques have allowed the detailed study of these carbon fibers. Formation of mold-like or vermicular-like carbon fibers grown at 300–900 °C had been frequently reported as an abnormal phenomenon, particularly in the carbon industry. At the same time, catalyst researchers had collected detailed data relating various metallic impurities and fibrous carbon (6). The tiny mold-like carbon fiber, although noted as a product of interesting catalytic effects, had not been applied commercially, such as in the production of composite materials.

Carbon fiber can be made from various compounds, including benzene, hexane, allenes, and carbon monoxide. Macroscopic and microscopic characteristics of these fibrous carbon products depend on the carbon source.

We have studied schemes to mass produce carbon fibers by growing them in the vapor phase, analyzed their properties and structures, and examined applications of them. VGCF has desirable properties and is potentially competitive with PAN- and pitch-based carbon fibers (7–9). VGCF may be a product that “carries knowledge into a new field.”

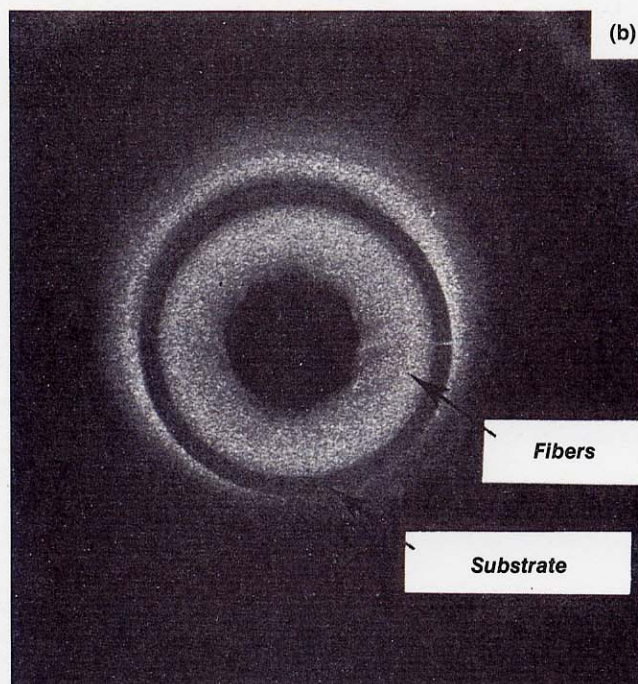
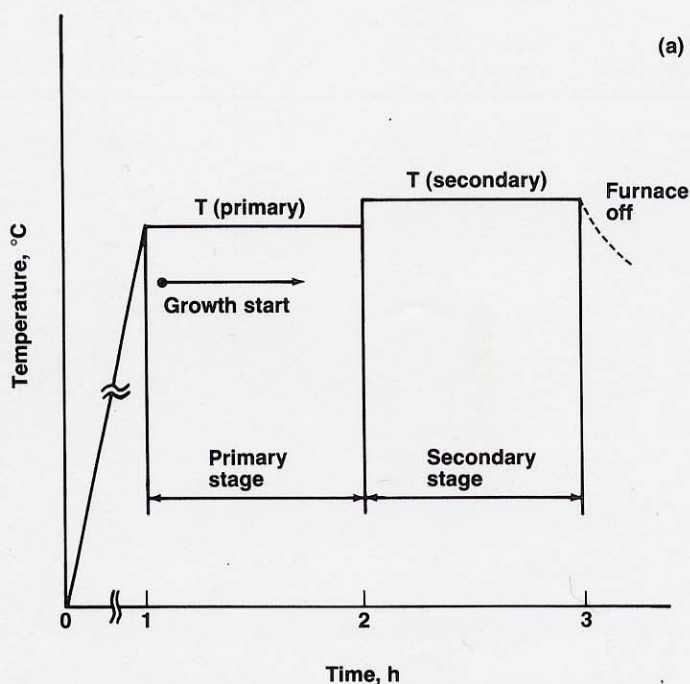

Figure 3. Temperature program (a); fiber growing in the furnace at 1100 °C (b)

Figure 2 depicts VGCF production equipment. A mixture of hydrogen and hydrocarbon is admitted into a reaction tube in an electrical furnace and kept around 1100 °C. Carbon fiber forms over a substrate in the reaction tube.

VGCF thus formed is grown in two steps: the fiber first forms over fine catalyst particles of iron or other relevant metals dispersed over the substrate; it then grows in the radial direction, resulting in fibers several decimeters long and about 10 μm in diameter. Temperature and timing are controlled throughout the process. Figure 3 shows temperature profiles and the fibers growing in the furnace. Note that VGCF is produced by a relatively simple system.

A scanning electron microscope (SEM) photograph of the fiber cross-section reveals a unique structure in which layers like growth rings lie concentrically on top of each other (Figure 4). VGCF has a circular cross-section and a preferred orientation in which networks of carbon planes are placed parallel to one another along the direction of the fiber axis. The orientational alignment is greater than those of conventional carbon fibers prepared in the same temperature range, which might account for the higher electrical conductivity and modulus of elasticity of VGCF.

One of the distinguishing structural features of VGCF is the presence of a hollow tube, about 10 nm or less in diameter, along the fiber axis (Figure 5a). The tube wall is composed of linearly extended, single-crystalline-like carbon layers, as shown in Figure 5c. Each layer, however, has a turbostratic stacking structure (i.e., is not a three-dimensional crystal) and does not form a three-dimensional graphite structure. The fiber periphery, on the other hand, is microcrystalline, in which two or three carbon basal networks are layered. This structure is common with thermally decomposed carbon films (Figure 5b). Thus it is apparent that the VGCF is composed of two different structures formed by different mechanisms: the catalytic growth of the fine, precursor fiber consisting of the hollow tube and linearly extended, parallel carbon

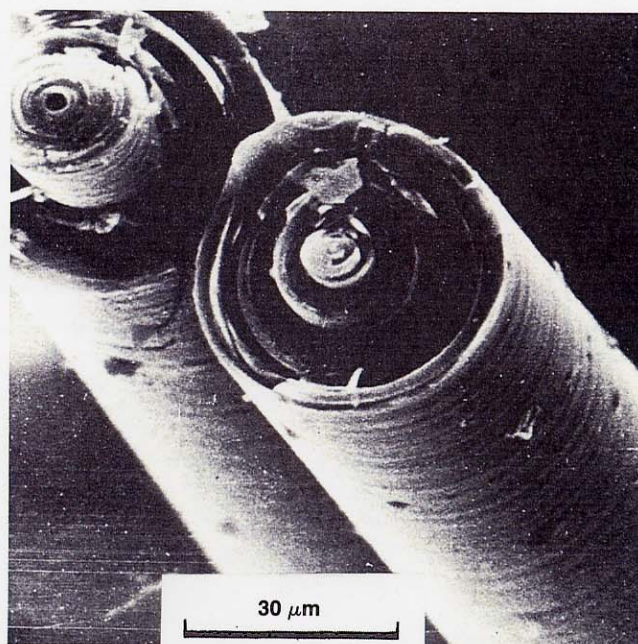

Figure 4. SEM Image of VGCF cross-section

layer faces near the fiber core; and the subsequent thermal decomposition of the hydrocarbons introduced by chemical vapor deposition that allows the fiber to grow in the radial direction. The physical properties of the resultant fibers are largely determined by the structures of the exterior region in thermal decomposition of hydrocarbons.

Mass production

The VGCF production process consists of three steps:

- seeding, in which ultrafine metallic catalyst particles serving as nuclei for the fiber growth are dispersed over the substrate surface,

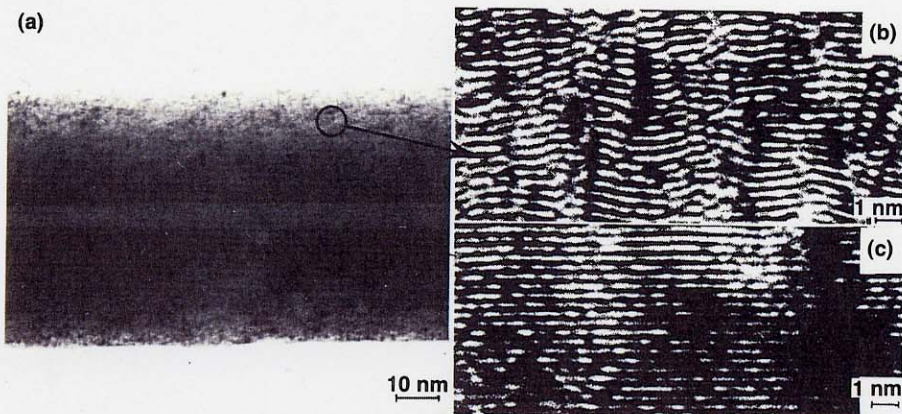
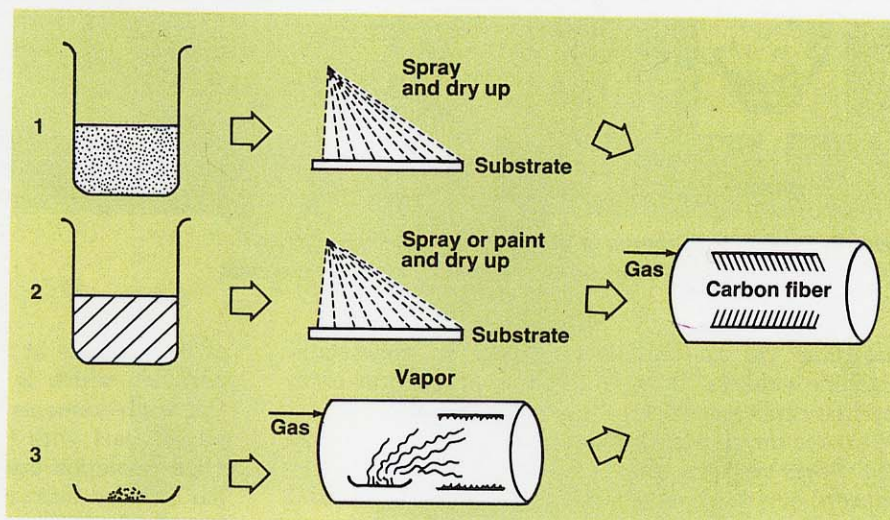

Figure 5. Hollow tube (a) and two different structures (b, c)

Figure 6. Substrate seeding methods



- growth of fine precursor fiber, and
- deposition of the thermally decomposed hydrocarbons over the precursor fiber to increase its radial size.

The dispersion of the fine catalyst particles, such as those of iron, is the key process for the mass production of VGCF. The seeding step largely determines the density of the growing fiber, i.e., the number of fibers per unit area of the substrate, and hence the productivity (7).

Figure 6 shows the three seeding approaches currently available. Approach 1 involves preparation of superfine particles of iron or other metals of 50 nm or less in size by an appropriate method such as evaporation in inert gas; the iron particles are suspended in alcohol to be sprayed and dried over a substrate. Particles having a magnetically or chemically active surface must be independently dispersed to achieve a dense growth of the fibers. Use of surfactants can promote uniform dispersion. Approach 2 attempts to spray a solution of a metal compound, such as iron nitrate, over a substrate; when heated to about 1100 °C in an electric furnace, ultrafine metal particles form. Approach 3 represents the direct seeding, in which ferrocene or other organic, metal-containing compounds are thermally decomposed and deposited over a substrate. This approach allows integration of the seeding with the subsequent fiber formation processes (9).

The seeded substrate is then heated in an electric furnace and a hydrogen-hydrocarbon mixture is passed over the substrate in a programmed process (Figure 3) to form VGCF (10 μm in diameter, 50–60 mm long). The density of the fiber formed in this manner will be about

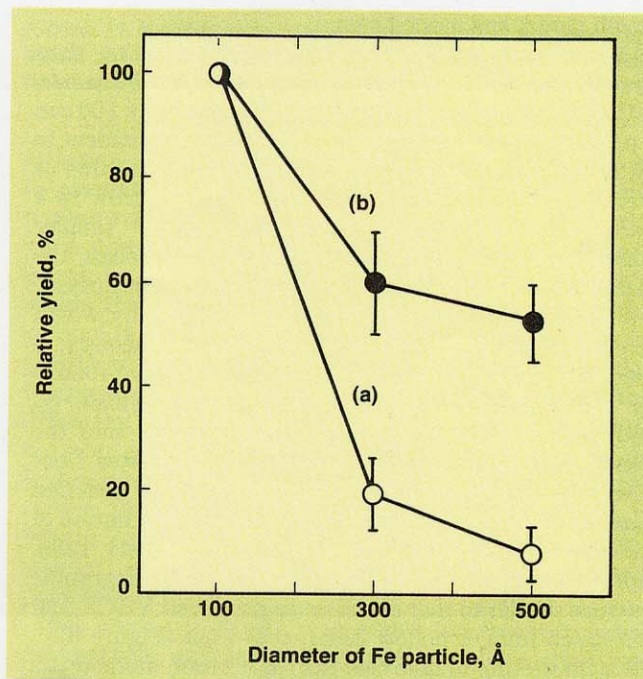

Figure 7. Effects of catalyst particle size on VGCF yield; catalyst with narrow (a) and broad (b) size distribution

600–1200 fibers/mm².

Fiber yield increases with smaller catalyst particle size (Figure 7). Growth rate of VGCF in the axial direction is 1–50 mm/min, which is 3–4 orders of magnitude higher

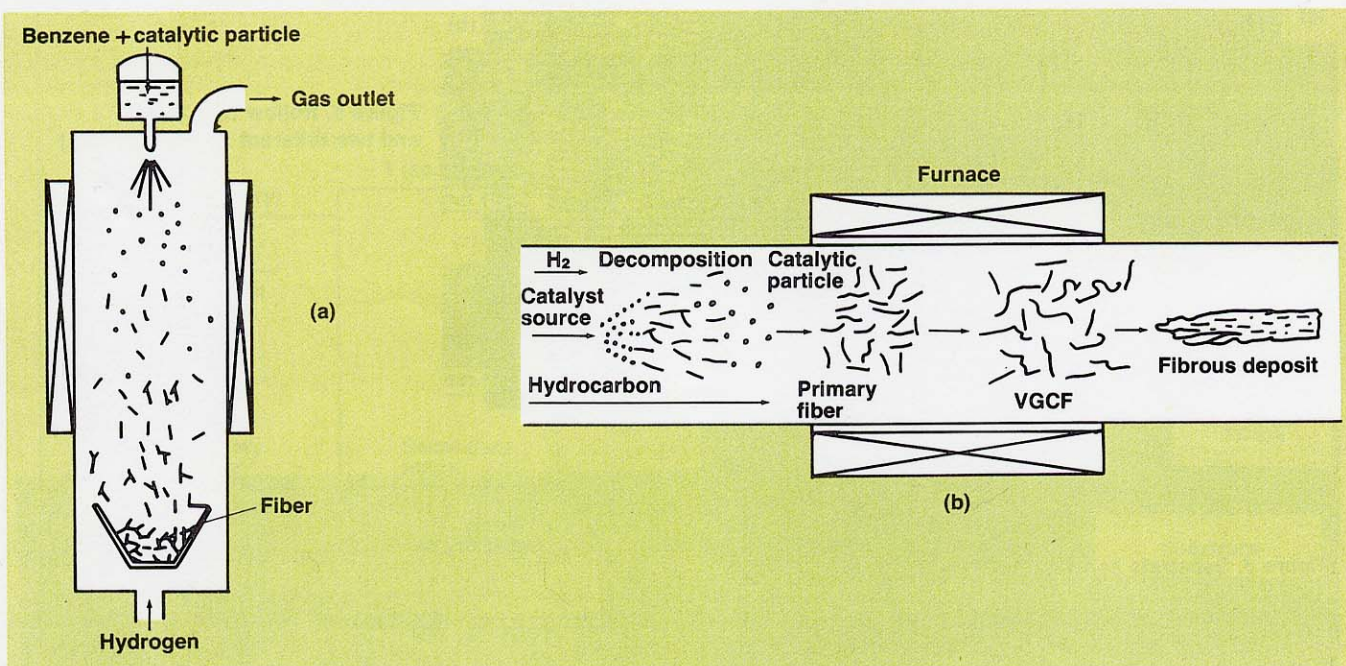

Figure 8. Conceptual scheme of VGCF production over fluidizing catalyst particles by direct (a) and indirect (b) methods

than those of conventional metallic or nonmetallic crystalline whiskers. This is largely due to the actions of the superfine catalyst particles.

We have developed fluidization seeding in which the initial fibers are formed over fluidized catalyst particles (Figure 8). It is much more efficient than substrate seeding for fiber formation (9).

Growth model and mechanism

As mentioned earlier, VGCF grows much faster than conventional whiskers, which grow at about $50 \mu\text{m/s}$. VGCF having an aspect ratio (length/diameter) of 100 can be produced in several seconds. This ratio is equivalent to that of commercial whiskers like SiC. A reaction time of several seconds is sufficient for fine fibers to grow in a hydrocarbon atmosphere with virus-size or smaller catalyst particles. In the fluidization seeding process, the catalyst may be introduced into the reactor either directly or indirectly (Figure 8). The indirect method, by which the catalyst particles and VGCF form simultaneously, is based on Approach 3 (Figure 6). It can efficiently produce fine particles of several tens of angstroms, which, by fluidizing ultrafine metal particles introduced into the reactor in a controlled manner, greatly promotes fiber growth in the three-dimensional space of the reaction chamber. Fluidization seeding permits better control of the catalyst-feed ratio and the product aspect ratio. Fluidization-produced VGCF has a crystallographic structure similar to that of substrate-produced VGCF, but with much smaller hollow tubes of 2–3 nm (Figure 9).

It is interesting to note that the fluidization method can produce carbon fibers ranging from carbon black-like fibers with an aspect ratio of about 1 to ordinary continuous fibers, in which the aspect ratio is essentially infinite. Products having low aspect ratios can be used as reinforcing agents for various matrices, such as rubber, plastics, and cement.

Figure 10 shows the tip of a growing fiber with a crystal

of iron carbide at the end of the hollow tube. The iron particle—which is either deposited on the substrate or fluidized—remains as it is while the fiber is growing but might react with the cementite particles when cooled. High-resolution transmission electron microscopy (TEM) has revealed that catalyst particles found at the fiber ends have fairly uniform sizes, mostly below 20–30 nm. Many fluidization-seeded particles are around 5 nm, which agrees with the observation that the fiber forms more efficiently with decreasing particle size. Baker and co-workers have reported that a finer particle grows the filamentous carbon faster (10), which may support our results for the ultrafine catalyst particles.

The fiber will continuously grow as long as the particles dispersed on the substrate or the fluidizing catalyst particles are active; the fiber ceases to grow when the particle surfaces are covered with carbon layers, oxygen, or other impurities, thus retarding movement of the carbon species. It is therefore vital to control the hydrocarbon partial pressure in the system and to keep the atmosphere free of impurities such as moisture and oxygen, in order to obtain long fibers. The TEM image (Figure 11) shows the catalyst particle at the end of the growing precursor fiber; it is not yet covered with hard, graphite-like carbon layers and can still actively assist fiber growth in the longitudinal direction. The resultant thin fibers have a continuous, thin, hollow tube as shown in Figure 11b.

We can illustrate the formation of VGCF by the model shown in Figure 12 (11). A reducing atmosphere of hydrogen at $\sim 1100^\circ\text{C}$ reduces the catalyst particle of a transition metal such as iron, or cleans its surface, which promotes the polymerization and condensation of the hydrocarbon to develop hexagonal planar networks of carbon. They grow perpendicular to the substrate surface in the space between the particle and the substrate. The particle is driven upward, away from the substrate—presumably by osmotic pressure, surface tension, or

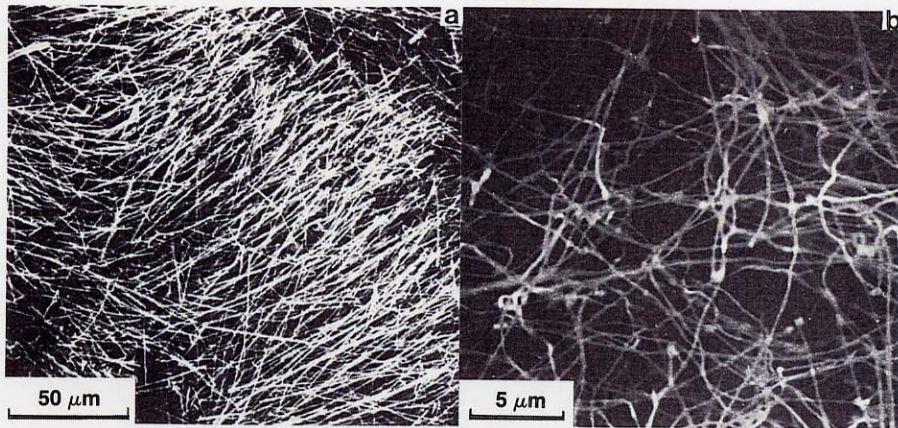

Figure 9. VGCF produced by the fluidized seeding method; straight (a) and vermiculate (b) fibers

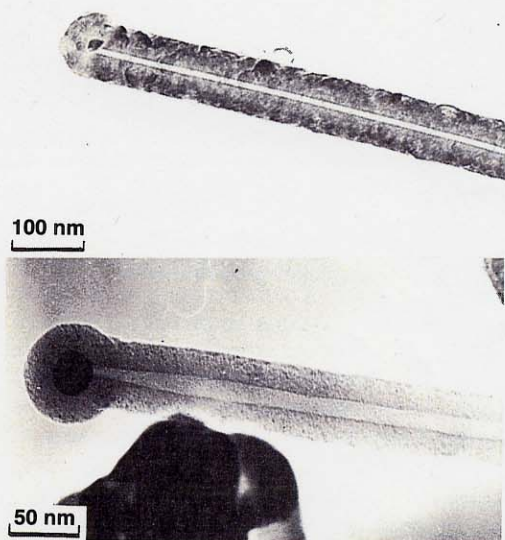

Figure 10. Microparticle (cementite) at the tip of the hollow tube

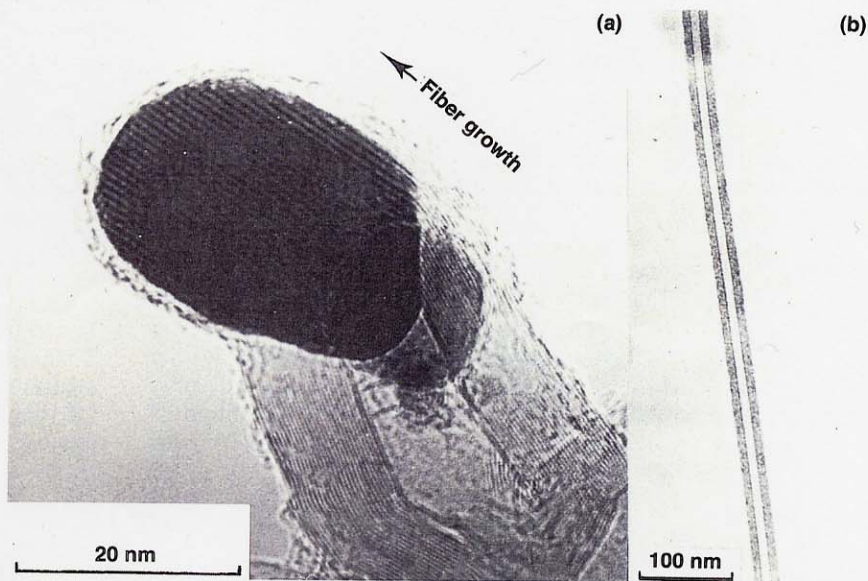

Figure 11. Seeded microparticle at the end of the growing VGCF (a) (from a collaboration with A. Oberlin) and a thin fiber with continuous hollow tube (b)

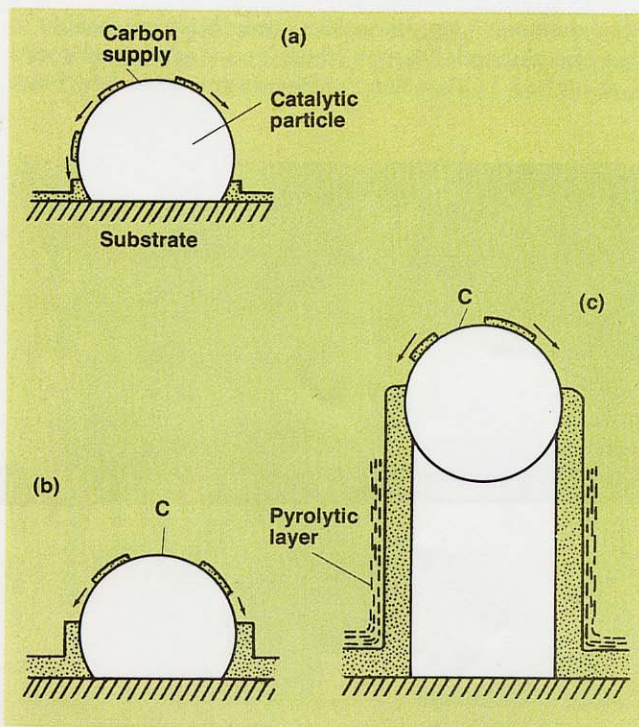

Figure 12. Proposed growth mechanisms of VGCF (11)

diffusion—and the precursor fiber formation is continued to elongate the fiber. The reactions occur in selective regions such as the surface of the catalyst particle or in some direction of the crystal. As the particle moves, it leaves behind the hollow tube. The carbon molecules within the particle move more briskly near the melting point of the catalyst, thus greatly contributing to the rapid growth of VGCF. It should be noted that the intraparticle temperature gradient provides an important force that drives the carbon species. This force, which consists of the net heat generated by the thermal decomposition of the hydrocarbon and the subsequent formation of solid carbon, promotes fiber formation. On the other hand, no fibrous carbon has been observed in net endothermic systems, such as those involving the decomposition of paraffins.

We don't yet clearly understand the extent to which intraparticle diffusion affects the overall reaction rate. Substrate seeding and fluidization seeding share common growth conditions and product structures, and, hence, growth mechanisms. If that is the case, the carbon layer plane should grow with a selective orientation for the fibrous matter to be formed over the fluidizing catalyst particles. It is therefore interesting to examine whether the catalytic effects show anisotropy. Audier (12) has studied

the formation of carbon fibers by the disproportionation of carbon monoxide ($2\text{CO} \rightarrow \text{CO}_2 + \text{C}$) and thermal decomposition of methane ($\text{CH}_4 \rightarrow 2\text{H}_2 + \text{C}$) over a Fe-Ni catalyst, and found that carbon is selectively absorbed on the specific crystal faces of the metal particles and separates out, after diffusing through the particles, to form fibrous carbon on the other faces (Figure 13) (12). The reaction temperature was fairly low (400–700 °C), and catalyst particles apparently remained solid throughout the process. It is possible that VGCF grows similarly at around 1100 °C over the solid particles.

However, we don't know yet whether each catalyst particle is in the form of a liquid droplet or a solid, nor do we know the extent to which the intraparticle temperature gradient influences VGCF formation. The net exothermic system for the formation of solid carbon from the hydrocarbon feed is also not clear, nor are the endothermic reactions involved or whether the intraparticle diffusion influences the overall reaction rate. These are some of more important questions to be solved before the growth model is fully developed.

Let me point out that the hydrogen that is used as a carrier gas plays an important role in the production of VGCF; product yield is significantly lower when nitrogen or argon is used in place of hydrogen. This means that hydrogen not only works to reduce the catalyst metal but also directly participates in the thermal decomposition of the hydrocarbons. Tesner and colleagues (13) reported that an acetylene-hydrogen mixture (10:90) yields ~20 times more carbon fiber than an acetylene-nitrogen mixture (10:90) over nichrome.

Industrial graphite whisker

Bacon produced graphite whiskers (2–3 cm long, 5 μm in diameter) by direct-current discharge of graphite electrodes under argon gas kept at 3900 K and 92 atm, near the triple point of graphite. For Bacon's graphite whisker, the c-axis of the crystallite crosses its fiber axis at 90°, so he proposed the structure shown in Figure 14, in which the graphite network planes are rolled into a scroll (5). It is not a single-crystalline whisker but can be regarded as single crystal with respect to its structure and properties along the fiber axis. It has an electrical resistivity comparable with that of single-crystal graphite. Its tensile strength of 20 GPa and modulus of elasticity of 700 GPa are the highest among those obtained so far and are close to the theoretically attainable levels of graphite. But Bacon's graphite whisker was developed under extreme conditions in very low production yield. It has not been commercially applied yet, but the work could be important to indicate the practical possible limit in strength of fibrous graphite.

VGCF is a typical graphitizing carbon; unlike pitch- and PAN-based fibers, it can be easily transformed by heat treatment into highly crystalline graphite. VGCF attains

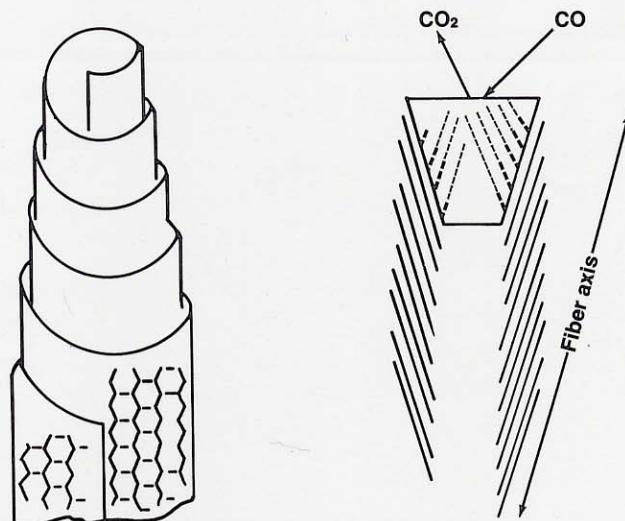

Figure 13 (left). Growth model of hollow-tube carbon fiber grown over solid metallic particle (12). Note that graphite layer faces are tilting at a certain angle to the fiber axis, as if a number of cones are placed one on another, a structure that may distinguish the fiber from VGCF

Figure 14 (right). Graphite whisker growth model (5)

an almost perfect graphite structure when heated at 3000 °C. The extent of the graphitization is higher than that of any other known fibrous carbon type. The graphite layer planes are arranged parallel to the fiber axis (Figure 15) (14) and can be easily produced on a commercial scale.

VGCF has desirable mechanical properties, although it is produced at the relatively low temperature of around 1100 °C. The product has almost the same properties, whether it is made from benzene or methane. Figure 16 presents the dependence of the tensile strength and modulus of elasticity of the methane-derived VGCF on fiber diameter (15). Its tensile strength is comparable to that of commercial carbon fibers, and it can be enhanced to as high as 7 GPa when the fiber is graphitized by heat.

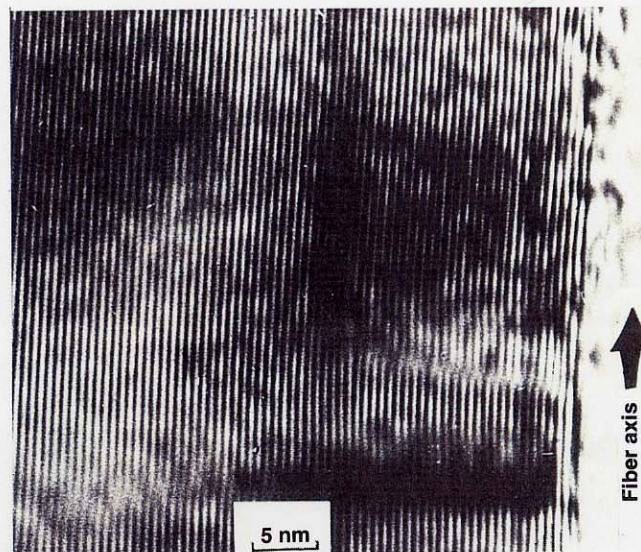

Figure 15. (002) lattice image of "graphite whisker" formed by treating VGCF at 2800–3000 °C

To this point, we have worked on improving the carbon fiber's mechanical properties. More recently, however, it has become imperative for researchers to direct their efforts to imparting novel functions to the fibers so as to widen their applications. VGCF has higher electrical and thermal conductivity than any other fiber; its resistivity at room temperature is $10^8 \mu\Omega \cdot \text{cm}$. When it is treated at 3000°C , its thermal conductivity at room temperature is about 4 times higher than that of copper (16). These properties, coupled with a high mechanical strength, will give unique properties to the composite materials it reinforces.

VGCF with rather thick diameters ($10 \mu\text{m}$) can be also used as a host material for graphite-intercalation compounds (GICs) (17), which can be made as conducting materials and are useful for battery electrodes. They can be used to strengthen synthetic metal wires and will have a much higher performance index (electrical conductivity/density). On the other hand, VGCF treated above 2900°C to form graphite fiber is best suited as a host material for GICs, which have low resistivity. For example, the GIC with AsF_5 has a resistivity of $1.1\text{--}3 \mu\Omega \cdot \text{cm}$ at room temperature and is relatively air stable. The latter GIC is thermally stable below 325°C and is applicable to various lightweight conducting composite materials. Furthermore, we have shown that the fluorine-intercalated VGCF is suitable as an active component for anodes of high-performance lithium batteries.

Future prospects

The inherent properties and structural characteristics of VGCF will make it a suitable material for various purposes (16). In particular, its mechanical, electrical, and thermal

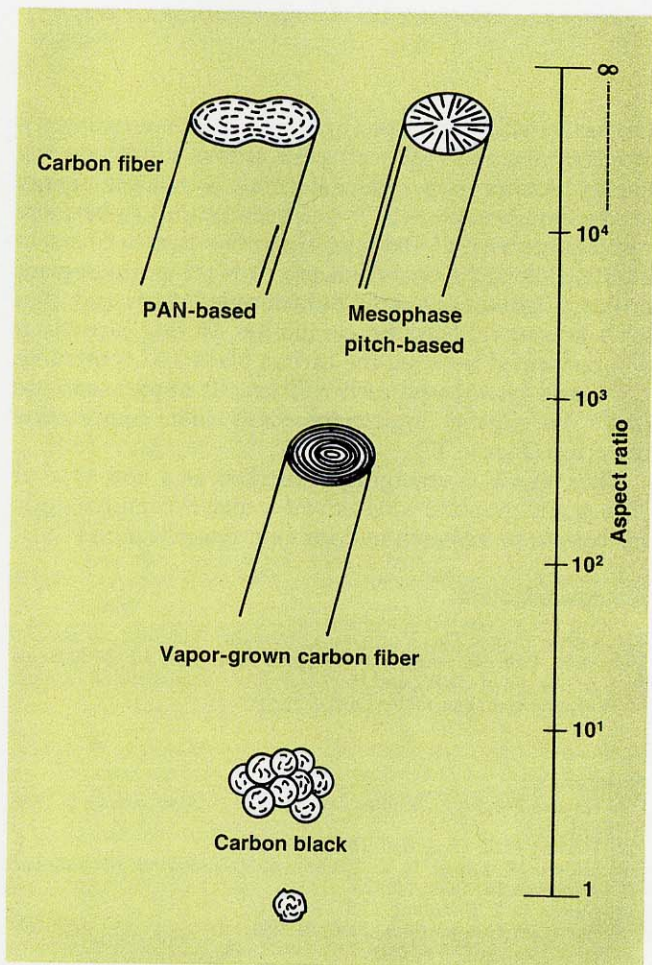

Figure 17. Comparison of aspect ratio as a filler material for composites

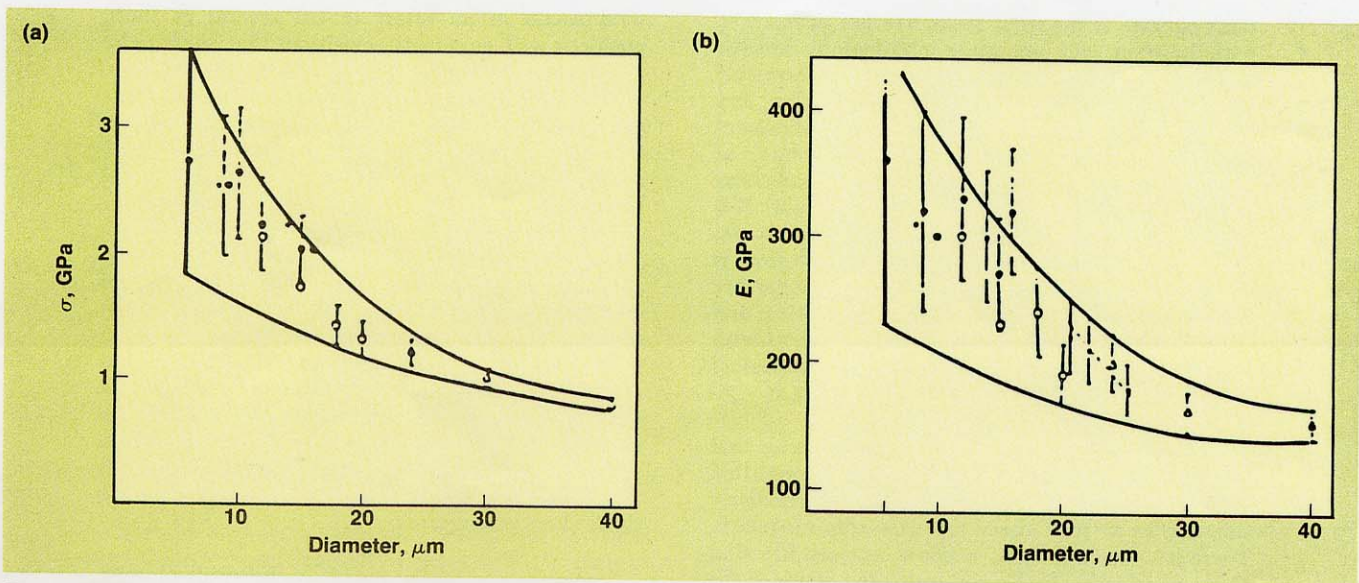

Figure 16. Dependence of tensile strength (σ) and modulus of elasticity (E) of VGCF on fiber diameter (15)

properties will further open up new application areas, such as electronics and high-tech areas related to biology and energy. Another area added recently is nuclear energy production, because VGCF has been proved to be more resistant to neutron irradiation than other carbon fibers. In addition, it could be sufficiently low-priced to replace ordinary carbon fibers in discontinuous yarn and thus serve as a useful filler for composites. In that capacity it will be located between the carbon black and continuous PAN- and pitch-based carbon fibers. Its applications are likely to expand into automobiles and construction materials (Figure 17).

Thus VGCF is emerging in markets as a new type of carbon and graphite whisker and is under extensive study for both basic research and for future applications.

Acknowledgment

The author thanks Dr. T. Koyama, Professor Emeritus of Shinshu University, Prof. M. Inagaki of Toyohashi University of Technology, Prof. A. Oberlin of CNRS, and Prof. M. S. Dresselhaus of MIT for their continuous encouragement and useful suggestion.

References

- (1) Schutzenberger, P.; Schutzenberger, L. *C. R. Acad. Sci. Paris* 1890, 111, 774.
- (2) Herring et al. *Phys. Rev.* 1952, 85, 1060.
- (3) Hillert, M.; Lange, N. *Z. Kristallogr. Kristallgeom. Kristallphys. Kristallchem.* 1958, 111, 24.
- (4) Meyer, L. *Z. Kristallog.* 1957, 109, 61.
- (5) Bacon, R. *J. Appl. Phys.* 1960, 21, 283.
- (6) Baker, R. T. K.; Harris, P. S. In *Chemistry and Physics of Carbon*; Walker, P. L., Jr.; Thrower, P. A., Eds.; Marcel Dekker: New York.
- (7) Endo, M.; Komaki, K.; Koyama, T. Presented to the International Symposium on Carbon, Toyohashi, Japan, 1982.
- (8) Endo, M.; Komaki, K. Presented to the 16th Biennial Conference on Carbon, University of California, 1983.
- (9) Endo, M.; Shikata, M. *Oyo Buturi* 1985, 54, 507.
- (10) Baker, R. T. K.; Harris, P. S.; Thomas, R. B.; Waite, R. J. *J. Catal.* 1973, 30, 86.
- (11) Oberlin, A.; Endo, M.; Koyama, T. *J. Crystal Growth* 1976, 32, 335.
- (12) Audier, M.; Coulon, M. *Carbon* 1985, 23, 317.
- (13) Tesner, P. A.; Robinovich, E. V.; Rafalkes, I. S.; Arefieva, E. F. *Carbon* 1970, 8, 435.
- (14) Chieu, T. C.; Dresselhaus, M. S.; Endo, M. *Phys. Rev.* 1982, 826, 5867.
- (15) Kandani, N.; Coulon, M.; Bonnetain, L. In *Extended Abstracts of Carbon '84*; Bordeaux, France, 1984; p. 142.
- (16) Piraux, L.; Nysten, B.; Haquenne, A.; Issi, J. P.; Dresselhaus, M. S.; Endo, M. *Solid State Commun.* 1984, 50, 697.
- (17) Dresselhaus, M. S.; Dresselhaus, G. *Adv. Phys.* 1981, 30, 136.
- (18) Tibbetts, C. G.; Endo, M.; Beetz, C. P., Jr. *SAMPE J.* 1986, 22-5, 30.



Morinobu Endo is Professor of Shinshu University (Faculty of Engineering, Shinshu University 500, Wakasato, Nagano, 380, Japan). His current work ranges from basic science to applications on vapor-grown and mesophase pitch-based carbon fibers, graphite intercalation compounds, and silicon carbide new ceramics. After receiving a M.S. degree from Shinshu University, he obtained a Ph.D. from Nagoya University. He has worked with A. Oberlin of CNRS, France, and M. S. Dresselhaus of MIT. He is editor of the *Japanese Carbon Society Journal*.

HELP WANTED

The environment in which technical professionals must operate is far from ideal. We are confronted with hesitant and uncertain political leadership, which in turn leads to an incoherent and certainly inconsistent national science policy. The key problems addressed by politicians and government today deal with such important matters as preventing war, controlling the economy, abolishing poverty, and providing a healthful environment. It is clear to us, but not to politicians nor our government, that central to the achievement of those desires is technological progress. Many of our industries are reacting to domestic and international political and marketing problems by focusing on short-term objectives to the detriment of technological development and productivity improvement, so vital to our nation.

The opportunities for further strengthening that position abound. One way is by proposing qualified engineers for service in government—particularly this year as we look ahead to a new administration. There is a very tight time window between Election Day and selection by federal transition teams of the people who will fill cabinet posts and other positions

at every level of government. ASME is now working with AAES in an effort to fill several of these positions with engineers—positions that *ought* to be filled with engineers.

We must continue to work hard to convince our members that their participation in government through testimony or through offering their expert advice is essential to the development of rational legislation.

There is an opportunity building for the ASME Council on Public Affairs to take a leadership position in advocating and contributing to the establishment of National Technological Goals. In my view, the philosophical debate that is raging on that subject is out of date. We can no longer afford to scatter our talents and resources in research and development as we have done in the past. We can no longer afford to live with the dismal performance in reducing innovation to practice. We must establish technological goals at a national level to alleviate those shortcomings.

Ernest L. Daman
President, ASME